

VARIANT® VX

The adjustable hinge system for heavy-duty doors



INDEX

VARIANT® VX – THE ADJUSTABLE HINGE SYSTEM FOR HEAVY-DUTY DOORS

12	VX 7939/100	rebated
13	VX 7939/120	
14	VX 7939/160 Planum	
15	VX 7939/160	
16	VX 7939/160 S WK MSTS	
17	VX 7939/160-4	
18	VX 7939/160-4 VBRplus	

19	VX 7728/100	rebated flush
20	VX 7728/120	
21	VX 7859/120	
22	VX 7728/160	
23	VX 7859/160-4	

24	VX 7729/100	unrebated
25	VX 7729/120	
26	VX 7729/160 Planum	
27	VX 7729/160-4 HA Set	
28	VX 7729/160	
29	VX 7729/160-4	
30	VX 7729/160-4 VBRplus	

31	VX 7749/160-4 Care	for health care facilities
----	---------------------------	----------------------------

VARIANT® VX – RECEIVERS

32	VX 2501 3D N	block frame
33	VX 7501 3D	
34	VX 7531 3D	

35	VX 2502 3D N	casing frame
36	VX 7502 3D	
37	VX 7532 3D	

38	VX 2505 3D N	blind frame
39	VX 7505 3D	
40	VX 7535 3D	

41	VX 2511 3D	steel frame
42	VX 7511/7512 3D + Cover Plate	

43	VX 7521 3D	aluminium frame
----	-------------------	-----------------

VARIANT® VX – COVER PLATES

44 **Series VX 2560 N** cover plates VX 25.. N series

45 **Series VX 2570 N**

46 **VX 2580 N**

47 **VX 2590 N**

48 **Series VX 7560** cover plates VX 75.. series

49 **VX 7561 KK**

50 **Series VX 7570**

51 **VX 7571 KK**

52 **VX 7580**

53 **VX 7581**

54 **VX 7590**

55 **VX 7591**

56 **Pin VN/VX 160 MSTs RC** accessories

58 **Load capacities**

60 **Options**

62 **Testing, approval, quality**

67 Service

VARIANT® VX – THE UNIVERSAL HINGE SYSTEM FOR HEAVY-DUTY DOORS

Universal applicability and an elegant appearance combined with a high technical standard are the outstanding features of the hinge system VARIANT VX. The hinge system has been developed for extremely high usage in heavy-duty applications and is characterised by high load capacities of up to 400 kg. In addition to maintenance-free slide bearing technology, VARIANT VX door hinges also offer the facility for three-dimensional adjustment on a permanently fixed door.

The large number of receiver elements from the VARIANT VX product range enables an extremely variable usage range with exceptionally simple adjustment options. Hinges from the VARIANT VX range are suitable for unrestricted use on fire doors.

The integral unit comprising hinge, receiver and cover provides the right type for each application, with approved safety. All VARIANT VX hinges are available as square cornered versions on request.

THE ADVANTAGES AT A GLANCE

- › for unrebated and rebated doors
 - › for timber, steel and aluminium frames
 - › 3D adjustable
 - › with load capacities up to 400 kg
-



Hinge

+



Receiver

+



Cover plate

VARIANT® VX – HINGE SYSTEMS



VARIANT® VX

for rebated, unrebated and rebated-flush heavy-duty doors
load capacities from 80 up to 400 kg



VARIANT® Planum

with reduced, elegant knuckle
load capacities up to 160 kg

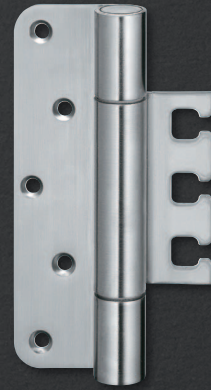

VARIANT® Heavy-Duty

for high performance heavy-duty doors
load capacities up to 400 kg



VARIANT® Timber/Alu

for timber/aluminium doors
load capacities up to 160 kg



Receivers VARIANT® VX

for block, casing, blind, steel and aluminium frames

VARIANT® VX – RECEIVER

The **VARIANT VX 25.. 3D N** series sets itself apart first and foremost through its pioneering 3D adjustability. Thanks to its innovative adjusting mechanisms, the door is fixed permanently in place throughout the adjustment process and can be moved into the correct position without sagging. Bolted to a base plate, the cover is guaranteed to support extremely heavy doors of up to 200 kg.

The receivers in the **VARIANT VX 75.. 3D** series come complete with a tried-and-tested adjusting mechanism. What's more, they can also accommodate load capacities of up to 200 kg thanks to the improved fixings within the receiver as well as on the frame.

The **VARIANT VX 753.. 3D** receiver series has been designed for particularly heavy loads. In conjunction with a suitable hinge and the appropriate cover plate, it can support load capacities of up to 400 kg on rebated and unrebated heavy-duty and functional doors with blind frames. Its three-dimensional, continuous adjustment options also make it an ideal choice for handling maximum load capacities.

Receiver



VX 2501 3D



VX 7502 3D



VX 7532 3D

VARIANT® VX – COVER PLATES

Cover plates

Even our range of cover plates leaves nothing to be desired. In addition to the well-known cover angles, which are now also available in a more widespread version for extreme load capacities, we now offer both designs as cover plates that are only visible from the frame side.

Cover angles

The cover angles are available in both angular and round designs in terms of both their angulation and ends. The designations for the cover angles are defined based on the following system: The first letter denotes the angulation, which is either angular (K) or rounded (R), (R3,5). The second letter describes the end of the cover angle. This can also be either angular (K) or rounded (R), (R6).

Cover plates



VX 7580



VX 7590

Cover angles



VX 7560 KK



VX 7570 KK





VARIANT® VX – HINGE ADJUSTABILITY

SIMONSWERK offers a complete series of 3D adjustable hinges for high frequency institutional, commercial and industrial applications such as office buildings, schools, hospitals and airports.

The VARIANT series has been developed for wide, heavy-duty doors that require a robust and stable hinge. High load capacities up to 400 kg distinguish this hinge system, as well as the maintenance-free slide bearing technology. The VARIANT series hinge systems offer a simple 3D adjustability feature allowing the installer to meet precise installation and maintenance requirements with the turn of an Allen key.

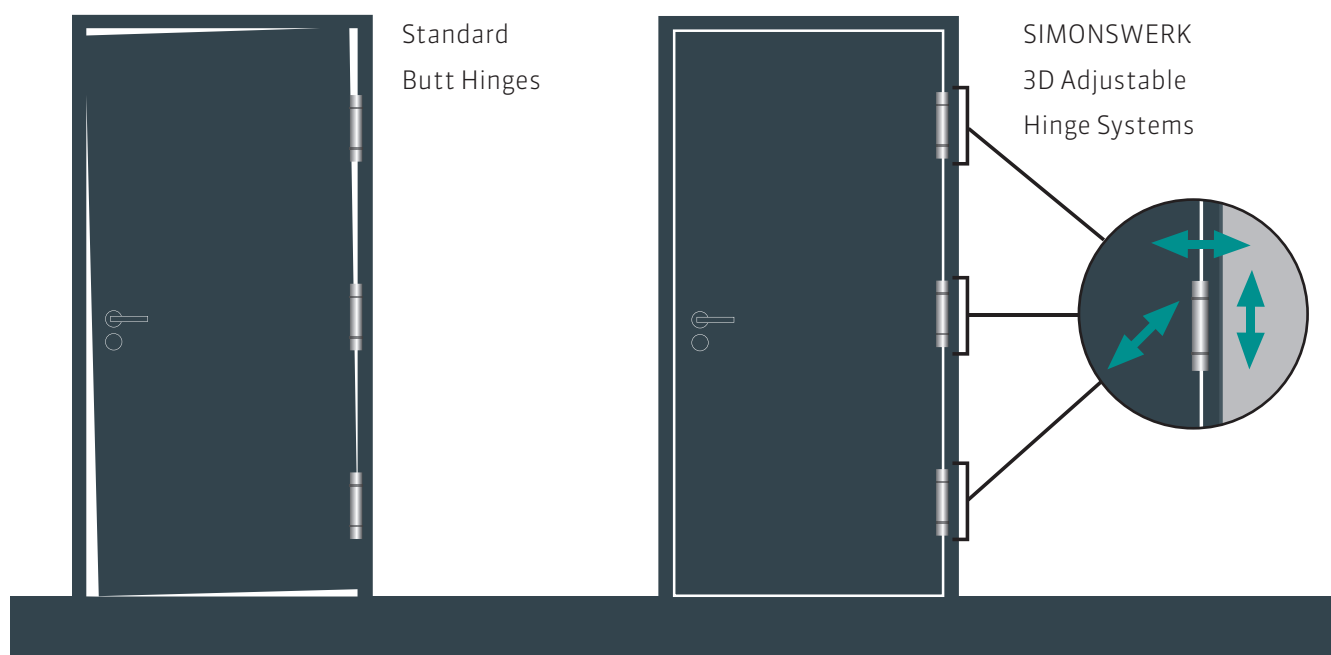



VARIANT® VX

VX 7939/100

for rebated heavy-duty doors

Hinge	rebated	up to 100 kg
-------	---------	--------------

Product features

- for rebated heavy-duty doors
- for timber, steel or aluminium frames
- for 3D adjustable VARIANT VX receivers
- internal torsion-proof pin
- concealed, maintenance-free axial-radial slide bearing

Technical details

load capacity	i 2 hinges per door leaf (1x2m)	100.0 kg
knuckle length		95.0 mm
knuckle diameter		20.0 mm
pin diameter		10.0 mm
material thickness		3.5 mm
cutter diameter		24.0 mm
recommended screws		5.0x50.0 mm

Finishes

blue galvanized (010), satin nickelled/F2 (018), polished brassed (030), satin chromed/F1 (037), Satin Stainless Steel (040), polished Stainless Steel (042), other finishes available upon request

Combination

receiver	block frame	VX 2501 3D N VX 7501 3D
	casing frame	VX 2502 3D N VX 7502 3D
blind frame		VX 2505 3D N VX 7505 3D
	steel frame	VX 2511 3D VX 7511 3D VX 7512 3D
	aluminium frame	VX 7521 3D

Installation tools

jig	universal milling frame
template	No. 5 250563 5

Functional areas

fire resistance, smoke resistance

Note

i The load capacity mentioned above refers to two hinges per door leaf (1 x 2 m). Also the load capacities of the respective combined receiver have to be taken into consideration.
Also available with security pin (MSTS).
Screws 4.5 x 50.0 mm can also be used as an alternative for lowering the depth.

Classification key

4	7	5	1*1	1	-*2	1	12
---	---	---	-----	---	-----	---	----

*1 Test evidence for functional doors to be achieved with full door sets and assemblies.

*2 depending on the finish

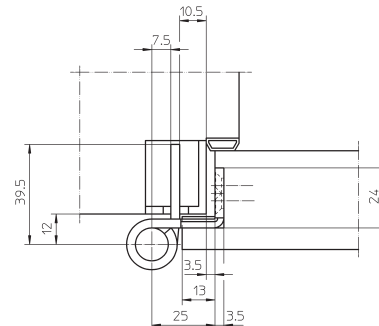
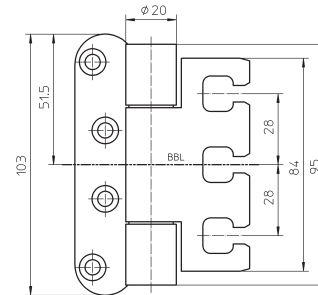

VARIANT® VX

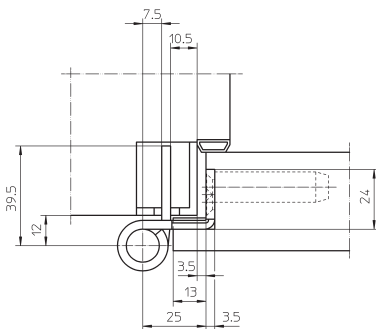
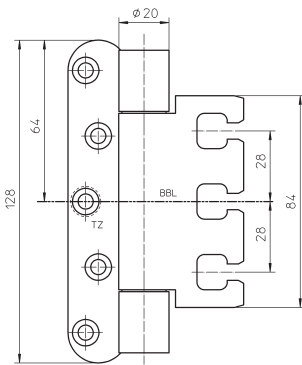

VX 7939/120

for rebated heavy-duty doors

Hinge	rebated	up to 120 kg
-------	---------	--------------

Product features

- for rebated heavy-duty doors
- for timber, steel or aluminium frames
- for 3D adjustable VARIANT VX receivers
- internal torsion-proof pin
- concealed, maintenance-free axial-radial slide bearing

Technical details

load capacity	i 2 hinges per door leaf (1x2m)	120.0 kg
knuckle length		120.0 mm
knuckle diameter		20.0 mm
pin diameter		10.0 mm
material thickness		3.5 mm
cutter diameter		24.0 mm
recommended screws		5.0x50.0 mm

Finishes

satin nickelled/F2 (018), polished brass (030), satin chromed/F1 (037), Satin Stainless Steel (040), polished Stainless Steel (042), RAL 9005 Matte Black (107), other finishes available upon request

Combination

receiver	block frame	VX 2501 3D N VX 7501 3D
	casing frame	VX 2502 3D N VX 7502 3D
blind frame	steel frame	VX 2505 3D N VX 7505 3D
	aluminium frame	VX 2511 3D VX 7511 3D VX 7512 3D VX 7521 3D

Installation tools

jig	universal milling frame
template	No. 5 250564 5

Functional areas

fire resistance, smoke resistance

Note

i The load capacity mentioned above refers to two hinges per door leaf (1 x 2 m). Also the load capacities of the respective combined receiver have to be taken into consideration.

Also available with security pin (MSTS).

Screws 4.5 x 50.0 mm can also be used as an alternative for lowering the depth.

Classification key

4	7	6	1*1	1	_*2	1	13
---	---	---	-----	---	-----	---	----

*1 Test evidence for functional doors to be achieved with full door sets and assemblies.

*2 depending on the finish

VARIANT® VX

VX 7939/160 Planum

for rebated heavy-duty doors with reduced, elegant knuckle

Hinge	rebated	up to 160 kg
-------	---------	--------------

Product features

- with reduced, elegant knuckle
- integral security pin
- for rebated heavy-duty doors
- for timber, steel or aluminium frames
- for 3D adjustable VARIANT VX receivers
- concealed, maintenance-free axial-radial slide bearings

Technical details

load capacity	i 2 hinges per door leaf (1x2m)	160.0 kg
knuckle length		160.0 mm
knuckle diameter		15.0 mm
material thickness		3.0 mm
cutter diameter		24.0 mm
recommended screws		5.0x50.0 mm

Finishes

polished brassed (030), satin chromed/F1 (037), Satin Stainless Steel (040), other finishes available upon request

Combination

receiver	block frame	VX 2501 3D N, VX 7501 3D
	casing frame	VX 2502 3D N
		VX 7502 3D
	blind frame	VX 2505 3D N
		VX 7505 3D
	steel frame	VX 2511 3D
VX 7511 3D		
VX 7512 3D		
aluminium frame	VX 7521 3D	

Installation tools

jig	universal milling frame
template	No. 5 250560 5

Functional areas

fire resistance, smoke resistance

Note

i The load capacity mentioned above refers to two hinges per door leaf (1 x 2 m). Also the load capacities of the respective combined receiver have to be taken into consideration.

Adapted for the application on doors within the high-class sector the elegant, diameter-reduced hinge knuckle is ideal for slim, recessed frame facings.

Screws 4.5 x 50.0 mm can also be used as an alternative for lowering the depth.

Classification key

4	7	5	1* ¹	1	-* ²	1	12* ³
---	---	---	-----------------	---	-----------------	---	------------------

*¹ Test evidence for functional doors to be achieved with full door sets and assemblies.

*² depending on the finish

*³ test cycles in continuous operation with 160 kg

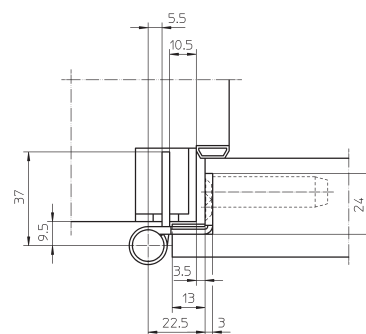
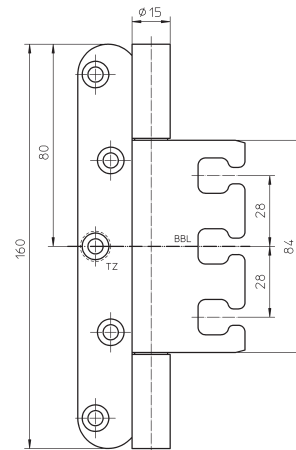

VARIANT® VX



VX 7939/160

for rebated heavy-duty doors

Hinge	rebated	up to 200 kg
-------	---------	--------------

Product features

- for rebated heavy-duty doors
- for timber, steel or aluminium frames
- for 3D adjustable VARIANT VX receivers
- internal torsion-proof pin
- concealed, maintenance-free axial-radial slide bearing

Technical details

load capacity	i 2 hinges per door leaf (1x2m)	200.0 kg
knuckle length		160.0 mm
knuckle diameter		22.5 mm
pin diameter		10.0 mm
material thickness		3.5 mm
cutter diameter		24.0 mm
recommended screws		5.0x50.0 mm

Finishes

blue galvanized (010), satin nickelled/F2 (018), polished brassed (030), satin chromed/F1 (037), Satin Stainless Steel (040), polished Stainless Steel (042), RAL 9005 Matte Black (107), Bronze Finish (174), Bronze Finish light (175), Bronze Finish dark (176), other finishes available upon request

Combination

receiver	block frame	VX 2501 3D N VX 7501 3D
	casing frame	VX 2502 3D N VX 7502 3D
blind frame	steel frame	VX 2505 3D N VX 7505 3D
	aluminium frame	VX 2511 3D VX 7511 3D VX 7512 3D VX 7521 3D

Installation tools

jig	universal milling frame
template	No. 5 250560 5

Functional areas

fire resistance, smoke resistance

Note

i The load capacity mentioned above refers to two hinges per door leaf (1 x 2 m). Also the load capacities of the respective combined receiver have to be taken into consideration. Also available with security pin (MSTS).

Classification key

4	7	7	1*1	1	_*2	1	14*3
---	---	---	-----	---	-----	---	------

*1 Test evidence for functional doors to be achieved with full door sets and assemblies.

*2 depending on the finish

*3 test cycles in continuous operation with 200 kg

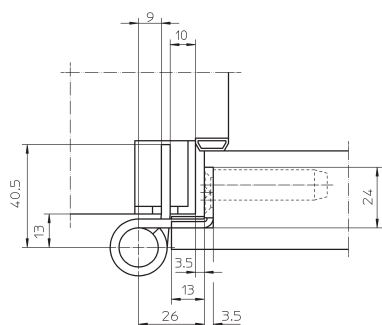
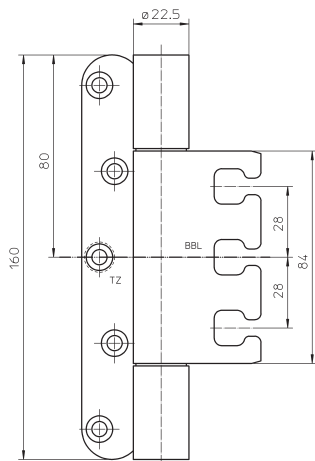

VARIANT® VX

VX 7939/160 S WK MSTS

for rebated, burglar resistant heavy-duty doors

Hinge	rebated	up to 200 kg
-------	---------	--------------

Product features

- with security pin and 2 welded security dowels
- for rebated, burglar resistant heavy-duty doors (resistance class)
- for timber, steel or aluminium frames
- for 3D adjustable VARIANT VX receivers
- internal torsion-proof pin
- concealed, maintenance-free axial-radial slide bearings

Technical details

load capacity	i 2 hinges per door leaf (1x2m)	200.0 kg
knuckle length		160.0 mm
knuckle diameter		22.5 mm
pin diameter		10.0 mm
material thickness		3.5 mm
cutter diameter		24.0 mm
recommended screws		5.0x50.0 mm

Finishes

satin nickelled/F2 (018), Satin Stainless Steel (040), other finishes available upon request

Combination

receiver	block frame	VX 7501 3D
	casing frame	VX 7502 3D
	blind frame	VX 7505 3D
	steel frame	VX 7511 3D
		VX 7512 3D
	aluminium frame	VX 7521 3D

Installation tools

jig	universal milling frame drilling jig VARIANT S-dowel
template	No. 5 250560 5

Functional areas

fire resistance, smoke resistance, burglar resistance

Note

i The load capacity mentioned above refers to two hinges per door leaf (1 x 2 m). Also the load capacities of the respective combined receiver have to be taken into consideration.

Security pin (MSTS) standard.

Screws 4.5 x 50.0 mm can also be used as an alternative for lowering the depth.

Classification key

4	7	7	1*1	1	-*2	1	14*3
---	---	---	-----	---	-----	---	------

*1 Test evidence for functional doors to be achieved with full door sets and assemblies.

*2 depending on the finish

*3 test cycles in continuous operation with 200 kg

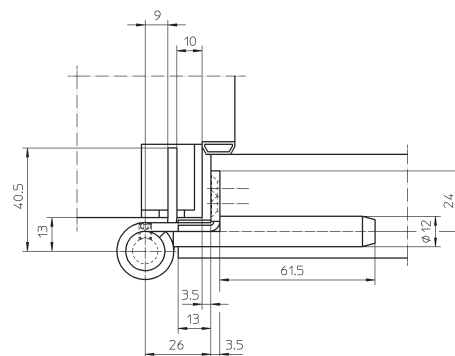
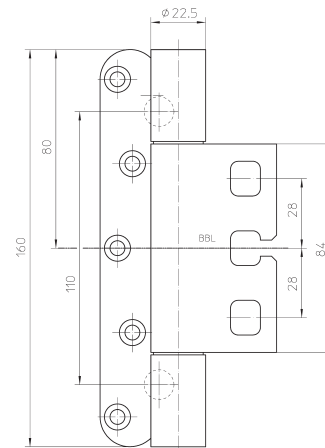

VARIANT® VX



VX 7939/160-4

for rebated high performance heavy-duty doors

Hinge	rebated	up to 300 kg
-------	---------	--------------

Product features

- for rebated heavy-duty doors
- for timber, steel or aluminium frames
- for 3D adjustable VARIANT VX receivers
- internal torsion-proof pin
- concealed, maintenance-free axial-radial slide bearing

Technical details

load capacity	i 2 hinges per door leaf (1x2m)	300.0 kg
knuckle length		160.0 mm
knuckle diameter		22.5 mm
pin diameter		10.0 mm
material thickness		4.0 mm
cutter diameter		24.0 mm
recommended screws		6.0x50.0 mm

Finishes

satin nickelled/F2 (018), Satin Stainless Steel (040), Stainless Steel/316 series (043), other finishes available upon request

Combination

receiver	block frame	VX 7531 3D
	casing frame	VX 7532 3D
	blind frame	VX 7535 3D
	steel frame	VX 2511 3D
		VX 7511 3D
		VX 7512 3D
	aluminium frame	VX 7521 3D

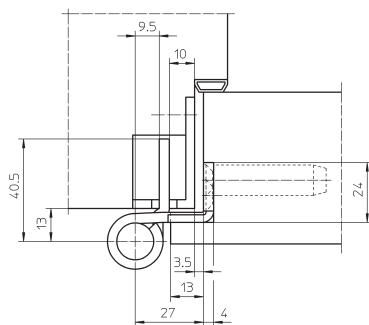
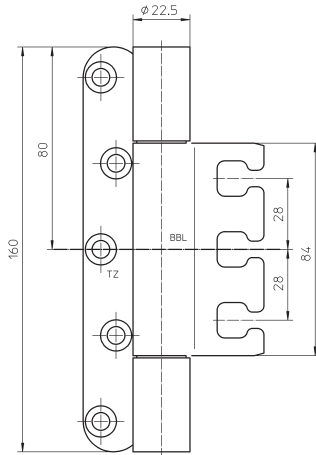

Installation tools

jig	universal milling frame
template	No. 5 250560 5

Functional areas

fire resistance, smoke resistance

Note

i The load capacity mentioned above refers to two hinges per door leaf (1 x 2 m). Also the load capacities of the respective combined receiver have to be taken into consideration.

Also available with security pin (MSTS).

Also available in stainless steel with material quality 316 series for an increased corrosion resistance.

Classification key

4	7	7	1* ¹	1	-* ²	1	14* ³
---	---	---	-----------------	---	-----------------	---	------------------

*¹ Test evidence for functional doors to be achieved with full door sets and assemblies.

*² depending on the finish

*³ test cycles in continuous operation with 300 kg

VARIANT® VX

VX 7939/160-4 VBRplus

with welded hinge knuckle for rebated, high performance heavy-duty doors

Hinge	rebated	up to 400 kg
-------	---------	--------------

Product features

- with welded hinge knuckle
- for rebated, extreme high performance heavy-duty doors
- for timber frames
- for 3D adjustable VARIANT VX receivers
- internal torsion-proof pin
- concealed, maintenance-free axial-radial slide bearing

Technical details

load capacity	i 2 hinges per door leaf (1x2m)	400.0 kg
knuckle length		160.0 mm
knuckle diameter		22.5 mm
pin diameter		10.0 mm
material thickness		4.0 mm
cutter diameter		24.0 mm
recommended screws		6.0x50.0 mm

Finishes

satin nickelled/F2 (018), Satin Stainless Steel (040), other finishes available upon request

Combination

receiver	block frame	VX 7531 3D
	casing frame	VX 7532 3D
	blind frame	VX 7535 3D

Installation tools

jig	universal milling frame
template	No. 5 250560 5

Functional areas

fire resistance, smoke resistance

Note

i The load capacity mentioned above refers to two hinges per door leaf (1 x 2 m). Also the load capacities of the respective combined receiver have to be taken into consideration.
Also available with security pin (MSTS).

Classification key

4	7	7	1* ¹	1	-* ²	1	14* ³
---	---	---	-----------------	---	-----------------	---	------------------

*¹ Test evidence for functional doors to be achieved with full door sets and assemblies.

*² depending on the finish

*³ test cycles in continuous operation with 400 kg

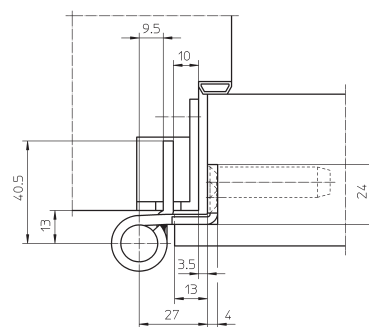
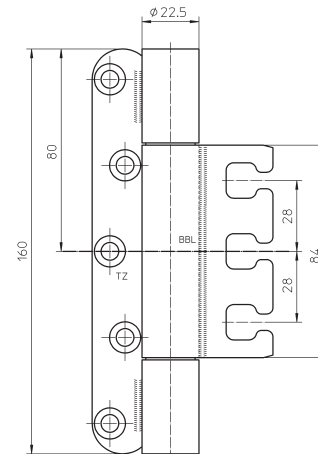

VARIANT® VX

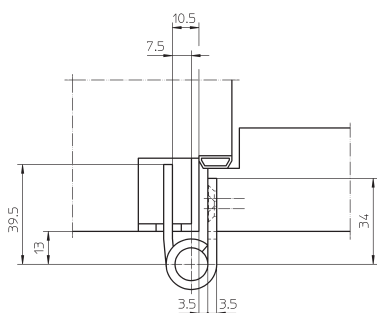
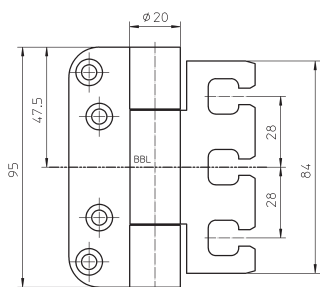
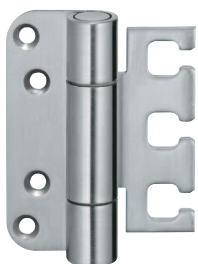

VX 7728/100

for rebated flush heavy-duty doors

Hinge	rebated flush	up to 80 kg
-------	---------------	-------------

Product features

- for rebated flush heavy-duty doors
- for timber, steel or aluminium frames
- for 3D adjustable VARIANT VX receivers
- internal torsion-proof pin
- concealed, maintenance-free axial-radial slide bearing

Technical details

load capacity	i 2 hinges per door leaf (1x2m)	80.0 kg
knuckle length		95.0 mm
knuckle diameter		20.0 mm
pin diameter		10.0 mm
material thickness		3.5 mm
cutter diameter		24.0 mm
recommended screws		5.0x50.0 mm

Finishes

satin nickelled/F2 (018), Satin Stainless Steel (040), other finishes available upon request

Combination

receiver	block frame	VX 2501 3D N VX 7501 3D
	casing frame	VX 2502 3D N VX 7502 3D
blind frame	steel frame	VX 2505 3D N VX 7505 3D
	aluminium frame	VX 2511 3D VX 7511 3D VX 7512 3D VX 7521 3D

Installation tools

jig	universal milling frame
template	No. 5 250566 5

Functional areas

fire resistance, smoke resistance

Note

i The load capacity mentioned above refers to two hinges per door leaf (1 x 2 m). Also the load capacities of the respective combined receiver have to be taken into consideration.

Also available with security pin (MSTS).

Screws 4.5 x 50.0 mm can also be used as an alternative for lowering the depth.

Classification key

4	7	5	1*1	1	-*2	1	12
---	---	---	-----	---	-----	---	----

*1 Test evidence for functional doors to be achieved with full door sets and assemblies.

*2 depending on the finish

VARIANT® VX

VX 7728/120

for rebated flush heavy-duty doors

Hinge	rebated flush	up to 100 kg
-------	---------------	--------------

Product features

- for rebated flush heavy-duty doors
- for timber, steel or aluminium frames
- for 3D adjustable VARIANT VX receivers
- internal torsion-proof pin
- concealed, maintenance-free axial-radial slide bearing

Technical details

load capacity	i 2 hinges per door leaf (1x2m)	100.0 kg
knuckle length		120.0 mm
knuckle diameter		20.0 mm
pin diameter		10.0 mm
material thickness		3.5 mm
cutter diameter		24.0 mm
recommended screws		5.0x50.0 mm

Finishes

satin nickelled/F2 (018), Satin Stainless Steel (040), other finishes available upon request

Combination

receiver	block frame	VX 2501 3D N VX 7501 3D
	casing frame	VX 2502 3D N VX 7502 3D
blind frame		VX 2505 3D N VX 7505 3D
	steel frame	VX 2511 3D VX 7511 3D VX 7512 3D
aluminium frame		VX 7521 3D

Installation tools

jig	universal milling frame
template	No. 5 250562 5

Functional areas

fire resistance, smoke resistance

Note

i The load capacity mentioned above refers to two hinges per door leaf (1 x 2 m). Also the load capacities of the respective combined receiver have to be taken into consideration.

Also available with security pin (MSTS).

Screws 4.5 x 50.0 mm can also be used as an alternative for lowering the depth.

Classification key

4	7	6	1*1	1	-*2	1	13
---	---	---	-----	---	-----	---	----

*1 Test evidence for functional doors to be achieved with full door sets and assemblies.

*2 depending on the finish

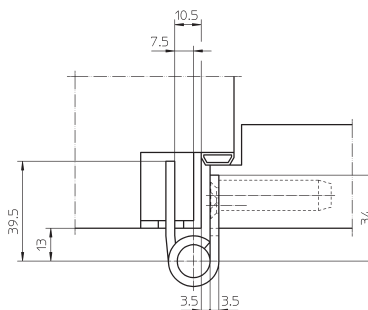
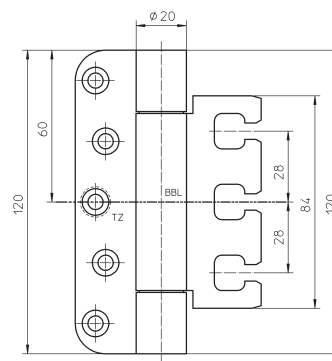
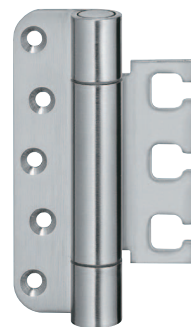

VARIANT® VX

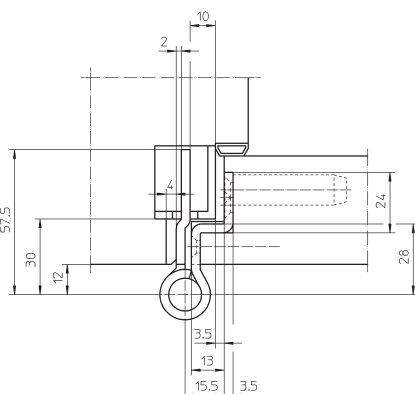
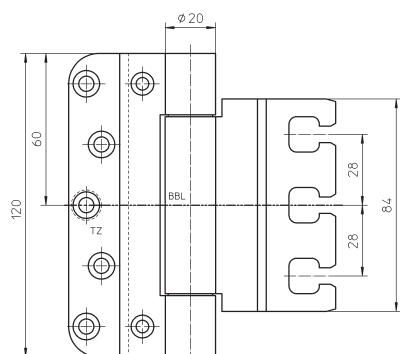
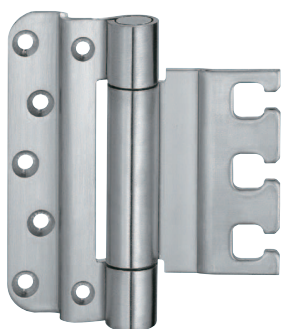

VX 7859/120

for rebated flush heavy-duty doors

Hinge	rebated flush	up to 100 kg
-------	---------------	--------------

Product features

- for rebated flush heavy-duty doors
- for timber, steel or aluminium frames
- for 3D adjustable VARIANT VX receivers
- internal torsion-proof pin
- concealed, maintenance-free axial-radial slide bearing

Technical details

load capacity	i 2 hinges per door leaf (1x2m)	100.0 kg
knuckle length		120.0 mm
knuckle diameter		20.0 mm
pin diameter		10.0 mm
material thickness		3.5 mm
cutter diameter		24.0 mm
recommended screws		5.0x50.0 mm

Finishes

Satin Stainless Steel (040), other finishes available upon request

Combination

receiver	block frame	VX 7531 3D
	casing frame	VX 7532 3D
	blind frame	VX 7535 3D
	steel frame	VX 2511 3D
		VX 7511 3D
		VX 7512 3D
	aluminium frame	VX 7521 3D

Installation tools

jig	universal milling frame
template	No. 5 250575 6

Functional areas

fire resistance, smoke resistance

Note

i The load capacity mentioned above refers to two hinges per door leaf (1 x 2 m). Also the load capacities of the respective combined receiver have to be taken into consideration.

Also available with security pin (MSTS).

Screws 4.5 x 50.0 mm can also be used as an alternative for lowering the depth.

Classification key

4	7	6	1*1	1	-*2	1	13
---	---	---	-----	---	-----	---	----

*1 Test evidence for functional doors to be achieved with full door sets and assemblies.

*2 depending on the finish

VARIANT® VX

VX 7728/160

for rebated flush heavy-duty doors

Hinge	rebated flush	up to 120 kg
-------	---------------	--------------

Product features

- for rebated flush heavy-duty doors
- for timber, steel or aluminium frames
- for 3D adjustable VARIANT VX receivers
- internal torsion-proof pin
- concealed, maintenance-free axial-radial slide bearing

Technical details

load capacity	i 2 hinges per door leaf (1x2m)	120.0 kg
knuckle length		160.0 mm
knuckle diameter		22.5 mm
pin diameter		10.0 mm
material thickness		3.5 mm
cutter diameter		24.0 mm
recommended screws		5.0x50.0 mm

Finishes

satin nickelled/F2 (018), Satin Stainless Steel (040), other finishes available upon request

Combination

receiver	block frame	VX 2501 3D N VX 7501 3D
	casing frame	VX 2502 3D N VX 7502 3D
blind frame		VX 2505 3D N VX 7505 3D
	steel frame	VX 2511 3D VX 7511 3D VX 7512 3D
aluminium frame		VX 7521 3D

Installation tools

jig	universal milling frame
template	No. 5 250561 5

Functional areas

fire resistance, smoke resistance

Note

i The load capacity mentioned above refers to two hinges per door leaf (1 x 2 m). Also the load capacities of the respective combined receiver have to be taken into consideration.

Also available with security pin (MSTS).

Screws 4.5 x 50.0 mm can also be used as an alternative for lowering the depth.

Classification key

4	7	7	1*1	1	-*2	1	13
---	---	---	-----	---	-----	---	----

*1 Test evidence for functional doors to be achieved with full door sets and assemblies.

*2 depending on the finish

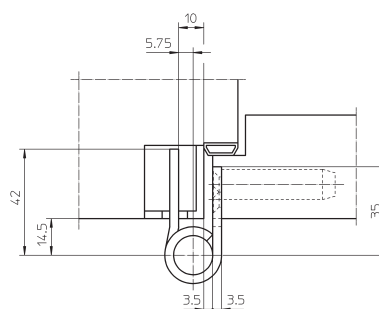
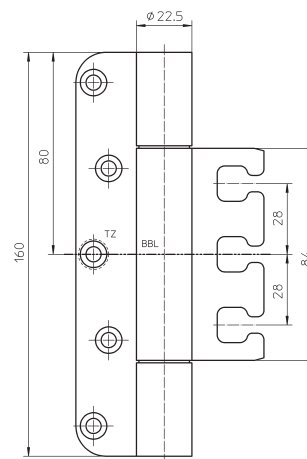
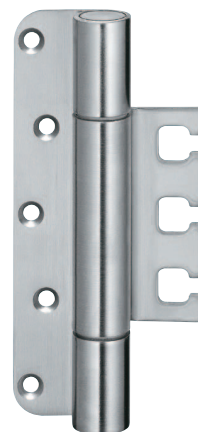

VARIANT® VX

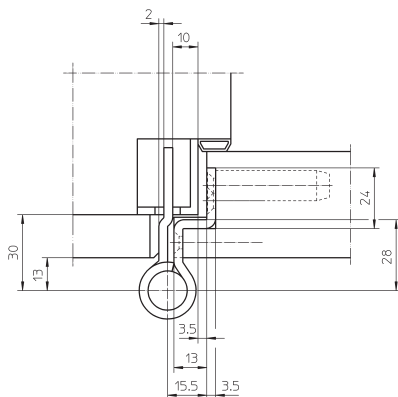
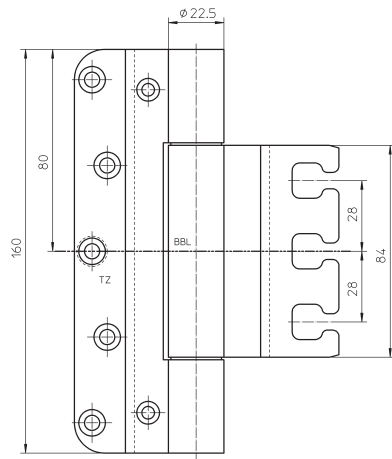
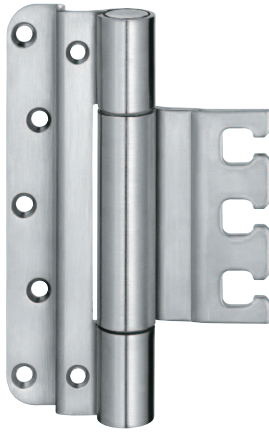

VX 7859/160-4

for rebated flush heavy-duty doors

Hinge	rebated flush	up to 120 kg
-------	---------------	--------------

Product features

- for rebated flush heavy-duty doors
- for timber, steel or aluminium frames
- for 3D adjustable VARIANT VX receivers
- internal torsion-proof pin
- concealed, maintenance-free axial-radial slide bearing

Technical details

load capacity	i 2 hinges per door leaf (1x2m)	120.0 kg
knuckle length		160.0 mm
knuckle diameter		22.5 mm
pin diameter		10.0 mm
material thickness		4.0 mm
cutter diameter		24.0 mm
recommended screws		6.0x50.0 mm

Finishes

satin nickelled/F2 (018), Satin Stainless Steel (040), other finishes available upon request

Combination

receiver	block frame	VX 7531 3D
	casing frame	VX 7532 3D
	blind frame	VX 7535 3D
	steel frame	VX 2511 3D
		VX 7511 3D
		VX 7512 3D
	aluminium frame	VX 7521 3D

Installation tools

jig	universal milling frame
template	No. 5 250577 6

Functional areas

fire resistance, smoke resistance

Note

i The load capacity mentioned above refers to two hinges per door leaf (1 x 2 m). Also the load capacities of the respective combined receiver have to be taken into consideration.

Also available with security pin (MSTS).

Classification key

4	7	7	1*1	1	-*2	1	14
---	---	---	-----	---	-----	---	----

*1 Test evidence for functional doors to be achieved with full door sets and assemblies.

*2 depending on the finish

VARIANT® VX

VX 7729/100

for unrebated heavy-duty doors

Hinge	unrebated	up to 100 kg
-------	-----------	--------------

Product features

- for unrebated heavy-duty doors
- for timber, steel or aluminium frames
- for 3D adjustable VARIANT VX receivers
- internal torsion-proof pin
- concealed, maintenance-free axial-radial slide bearing

Technical details

load capacity	i 2 hinges per door leaf (1x2m)	100.0 kg
knuckle length		95.0 mm
knuckle diameter		20.0 mm
pin diameter		10.0 mm
material thickness		3.5 mm
cutter diameter		24.0 mm
recommended screws		5.0x50.0 mm

Finishes

blue galvanized (010), satin nickelled/F2 (018), polished brassed (030), satin chromed/F1 (037), Satin Stainless Steel (040), polished Stainless Steel (042), other finishes available upon request

Combination

receiver	block frame	VX 2501 3D N VX 7501 3D
	casing frame	VX 2502 3D N VX 7502 3D
blind frame		VX 2505 3D N VX 7505 3D
	steel frame	VX 2511 3D VX 7511 3D VX 7512 3D
aluminium frame		VX 7521 3D

Installation tools

jig	universal milling frame
template	No. 5 250565 5

Functional areas

fire resistance, smoke resistance

Note

i The load capacity mentioned above refers to two hinges per door leaf (1 x 2 m). Also the load capacities of the respective combined receiver have to be taken into consideration.
Also available with security pin (MSTS).
Screws 4.5 x 50.0 mm can also be used as an alternative for lowering the depth.

Classification key

4	7	5	1*1	1	-*2	1	12
---	---	---	-----	---	-----	---	----

*1 Test evidence for functional doors to be achieved with full door sets and assemblies.

*2 depending on the finish

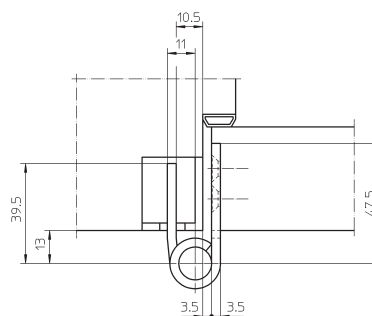
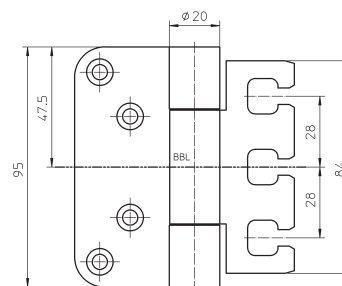
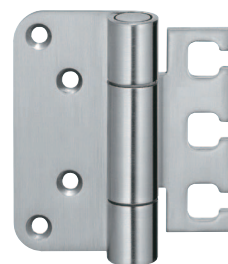

VARIANT® VX

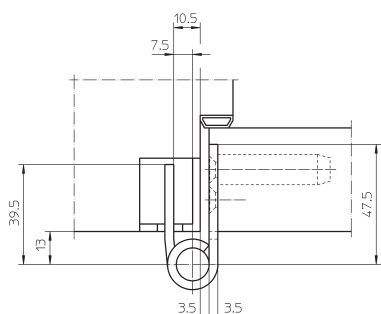
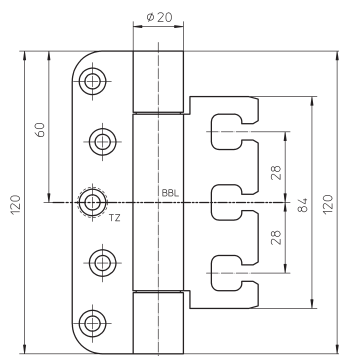

VX 7729/120

for unrebbated heavy-duty doors

Hinge	unrebbated	up to 120 kg
-------	------------	--------------

Product features

- for unrebbated heavy-duty doors
- for timber, steel or aluminium frames
- for 3D adjustable VARIANT VX receivers
- internal torsion-proof pin
- concealed, maintenance-free axial-radial slide bearing

Technical details

load capacity	i 2 hinges per door leaf (1x2m)	120.0 kg
knuckle length		120.0 mm
knuckle diameter		20.0 mm
pin diameter		10.0 mm
material thickness		3.5 mm
cutter diameter		24.0 mm
recommended screws		5.0x50.0 mm

Finishes

blue galvanized (010), satin nickelled/F2 (018), polished brassed (030), satin chromed/F1 (037), Satin Stainless Steel (040), polished Stainless Steel (042), RAL 9005 Matte Black (107), other finishes available upon request

Combination

receiver	block frame	VX 2501 3D N VX 7501 3D
	casing frame	VX 2502 3D N VX 7502 3D
blind frame	steel frame	VX 2505 3D N VX 7505 3D
	aluminium frame	VX 2511 3D VX 7511 3D VX 7512 3D VX 7521 3D

Installation tools

jig	universal milling frame
template	No. 5 250354 5

Functional areas

fire resistance, smoke resistance

Note

i The load capacity mentioned above refers to two hinges per door leaf (1 x 2 m). Also the load capacities of the respective combined receiver have to be taken into consideration.

Also available with security pin (MSTS).

Screws 4.5 x 50.0 mm can also be used as an alternative for lowering the depth.

Classification key

4	7	6	1*1	1	_*2	1	12
---	---	---	-----	---	-----	---	----

*1 Test evidence for functional doors to be achieved with full door sets and assemblies.

*2 depending on the finish

VARIANT® VX

VX 7729/160 Planum

with reduced, elegant knuckle for unrebated heavy-duty doors

Hinge	unrebated	up to 160 kg
-------	-----------	--------------

Product features

- with reduced, elegant knuckle
- integral security pin
- for unrebated heavy-duty doors
- for timber, steel or aluminium frames
- for 3D adjustable VARIANT VX receivers
- concealed, maintenance-free axial-radial slide bearings

Technical details

load capacity	i 2 hinges per door leaf (1x2m)	160.0 kg
knuckle length		160.0 mm
knuckle diameter		15.0 mm
material thickness		3.0 mm
cutter diameter		24.0 mm
recommended screws		5.0x50.0 mm

Finishes

satin chromed/F1 (037), Satin Stainless Steel (040), polished Stainless Steel (042), other finishes available upon request

Combination

receiver	block frame	VX 2501 3D N, VX 7501 3D
	casing frame	VX 2502 3D N VX 7502 3D
	blind frame	VX 2505 3D N VX 7505 3D
	steel frame	VX 2511 3D VX 7511 3D VX 7512 3D
	aluminium frame	VX 7521 3D

Installation tools

jig	universal milling frame
template	No. 5 250353 5

Functional areas

fire resistance, smoke resistance

Note

i The load capacity mentioned above refers to two hinges per door leaf (1 x 2 m). Also the load capacities of the respective combined receiver have to be taken into consideration.

Adapted for the application on doors within the high-class sector the elegant, diameter-reduced hinge knuckle is ideal for slim, recessed frame facings.

Screws 4.5 x 50.0 mm can also be used as an alternative for lowering the depth.

Classification key

4	7	5	1* ¹	1	-* ²	1	12* ³
---	---	---	-----------------	---	-----------------	---	------------------

*¹ Test evidence for functional doors to be achieved with full door sets and assemblies.

*² depending on the finish

*³ test cycles in continuous operation with 160 kg

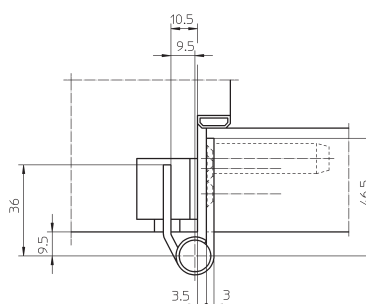
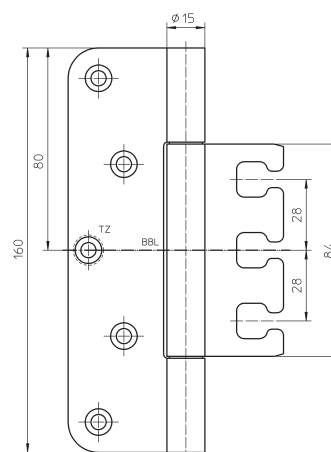
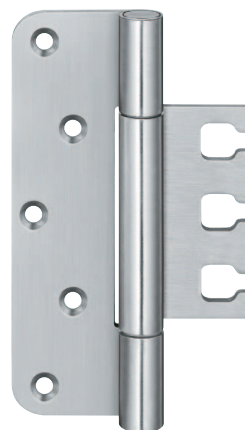

VARIANT® VX

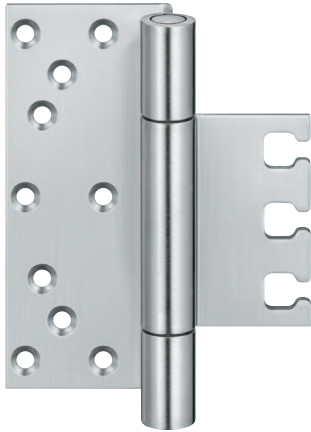

VX 7729/160-4 HA Set

consisting of knuckle hinge, receiver and cover angle

Hinge	unrebated	up to 160 kg
--------------	------------------	---------------------

Product features

- with welded hinge knuckle
- with security pin
- for timber/aluminium doors
- for 3D adjustable receivers VARIANT VX 7531 3D and VX 7535 3D
- internal torsion-proof pin
- concealed, maintenance-free axial-radial slide bearings

Technical details

load capacity	i 2 hinges per door leaf (1x2m)	160.0 kg
knuckle length		160.0 mm
knuckle diameter		22.5 mm
material thickness		4.0 mm
recommended screws		6.0x50.0 mm

Finishes

Satin Stainless Steel (040), other finishes available upon request

Combination

receiver	block frame	VX 7531 3D
	blind frame	VX 7535 3D

Installation tools

jig	drilling jig VARIANT VX 7531 3D
	drilling jig VARIANT VX 7729/160-4 HA

Note

i The load capacity mentioned above refers to two hinges per door leaf (1 x 2 m). Also the load capacities of the respective combined receiver have to be taken into consideration.

Scope of supply

Set 1 (cover angle KK)	Hinge	VX 7729/160-4 HA MSTs
	receiver	VX 7531 3D
	cover angle	VX 7561 KK
Set 2 (cover angle KR)	Hinge	VX 7729/160-4 HA MSTs
	receiver	VX 7531 3D
	cover angle	VX 7561 KR

Further combinations available upon request



E.g. receiver VX 7531 3D



E.g. cover angle
VX 7561 KK

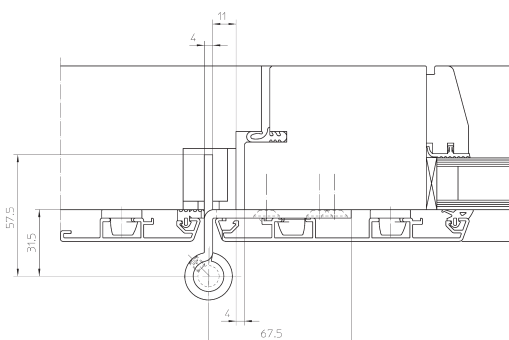

VARIANT® VX

VX 7729/160

for unrebated heavy-duty doors

Hinge	unrebated	up to 200 kg
-------	-----------	--------------

Product features

- for unrebated heavy-duty doors
- for timber, steel or aluminium frames
- for 3D adjustable VARIANT VX receivers
- internal torsion-proof pin
- concealed, maintenance-free axial-radial slide bearing

Technical details

load capacity	i 2 hinges per door leaf (1x2m)	200.0 kg
knuckle length		160.0 mm
knuckle diameter		22.5 mm
pin diameter		10.0 mm
material thickness		3.5 mm
cutter diameter		24.0 mm
recommended screws		5.0x50.0 mm

Finishes

blue galvanized (010), satin nickelled/F2 (018), polished brass (030), satin chromed/F1 (037), Satin Stainless Steel (040), polished Stainless Steel (042), RAL 9005 Matte Black (107), Bronze Finish (174), Bronze Finish light (175), Bronze Finish dark (176), other finishes available upon request

Combination

receiver	block frame	VX 2501 3D N VX 7501 3D
	casing frame	VX 2502 3D N VX 7502 3D
blind frame		VX 2505 3D N VX 7505 3D
	steel frame	VX 2511 3D VX 7511 3D VX 7512 3D
aluminium frame		VX 7521 3D

Installation tools

jig	universal milling frame
template	No. 5 250353 5

Functional areas

fire resistance, smoke resistance

Note

i The load capacity mentioned above refers to two hinges per door leaf (1 x 2 m). Also the load capacities of the respective combined receiver have to be taken into consideration.
Also available with security pin (MSTS).
Screws 4.5 x 50.0 mm can also be used as an alternative for lowering the depth.

Classification key

4	7	7	1*1	1	-*2	1	14*3
---	---	---	-----	---	-----	---	------

*1 Test evidence for functional doors to be achieved with full door sets and assemblies.

*2 depending on the finish

*3 test cycles in continuous operation with 200 kg

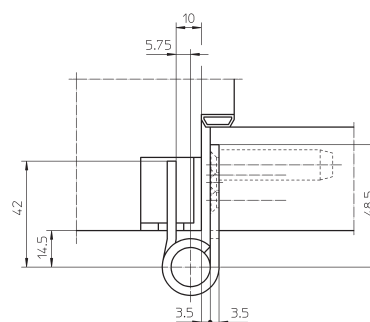
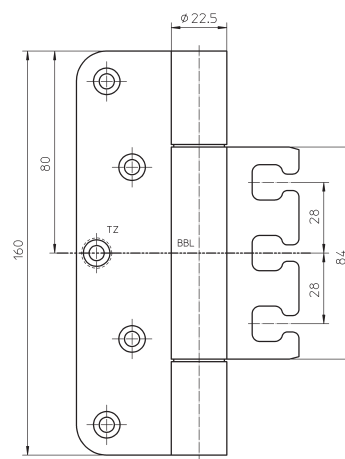
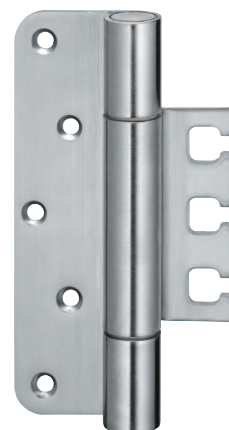

VARIANT® VX

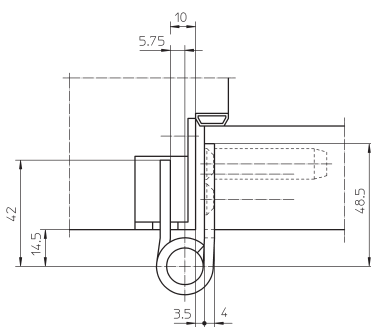
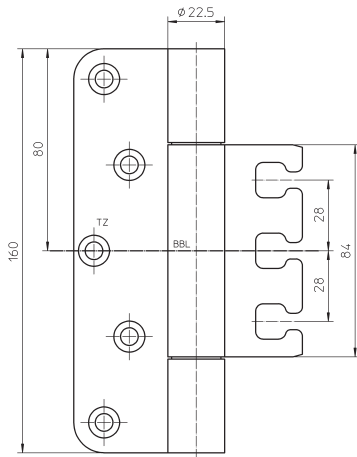
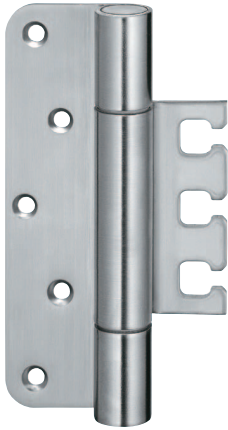

VX 7729/160-4

for unrebated high performance heavy-duty doors

Hinge	unrebated	up to 300 kg
-------	-----------	--------------

Product features

- for unrebated heavy-duty doors
- for timber, steel or aluminium frames
- for 3D adjustable VARIANT VX receivers
- internal torsion-proof pin
- concealed, maintenance-free axial-radial slide bearing

Technical details

load capacity	i 2 hinges per door leaf (1x2m)	300.0 kg
knuckle length		160.0 mm
knuckle diameter		22.5 mm
pin diameter		10.0 mm
material thickness		4.0 mm
cutter diameter		24.0 mm
recommended screws		6.0x50.0 mm

Finishes

satin nickelled/F2 (018), Satin Stainless Steel (040), Stainless Steel/316 series (043), other finishes available upon request

Combination

receiver	block frame	VX 7531 3D
	casing frame	VX 7532 3D
	blind frame	VX 7535 3D
	steel frame	VX 2511 3D
		VX 7511 3D
		VX 7512 3D
	aluminium frame	VX 7521 3D

Installation tools

jig	universal milling frame
template	No. 5 250353 5

Functional areas

fire resistance, smoke resistance

Note

i The load capacity mentioned above refers to two hinges per door leaf (1 x 2 m). Also the load capacities of the respective combined receiver have to be taken into consideration.

Also available with security pin (MSTS).

Also available in stainless steel with material quality 316 series for an increased corrosion resistance.

Classification key

4	7	7	1*1	1	-*2	1	14*3
---	---	---	-----	---	-----	---	------

*1 Test evidence for functional doors to be achieved with full door sets and assemblies.

*2 depending on the finish

*3 test cycles in continuous operation with 300 kg

VARIANT® VX

VX 7729/160-4 VBRplus

with welded hinge knuckle for unrebated, high performance heavy-duty doors

Hinge	unrebated	up to 400 kg
-------	-----------	--------------

Product features

- with welded hinge knuckle
- for unrebated, extreme high performance heavy-duty doors
- for timber frames
- for 3D adjustable VARIANT VX receivers
- internal torsion-proof pin
- concealed, maintenance-free axial-radial slide bearing

Technical details

load capacity	i 2 hinges per door leaf (1x2m)	400.0 kg
knuckle length		160.0 mm
knuckle diameter		22.5 mm
pin diameter		10.0 mm
material thickness		4.0 mm
cutter diameter		24.0 mm
recommended screws		6.0x50.0 mm

Finishes

satin nickelled/F2 (018), Satin Stainless Steel (040), other finishes available upon request

Combination

receiver	block frame	VX 7531 3D
	casing frame	VX 7532 3D
	blind frame	VX 7535 3D

Installation tools

jig	universal milling frame
template	No. 5 250353 5

Functional areas

fire resistance, smoke resistance

Note

i The load capacity mentioned above refers to two hinges per door leaf (1 x 2 m). Also the load capacities of the respective combined receiver have to be taken into consideration.
Also available with security pin (MSTS).

Classification key

4	7	7	1*1	1	-*2	1	14*3
---	---	---	-----	---	-----	---	------

*1 Test evidence for functional doors to be achieved with full door sets and assemblies.

*2 depending on the finish

*2 test cycles in continuous operation with 400 kg

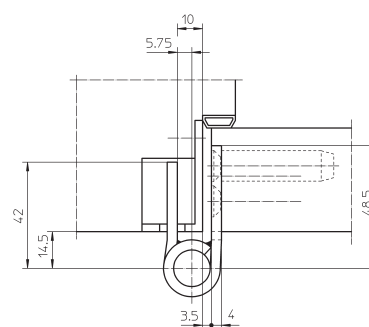
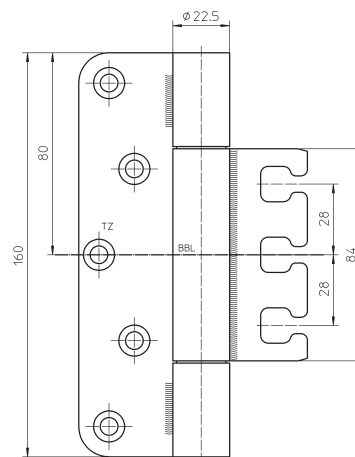
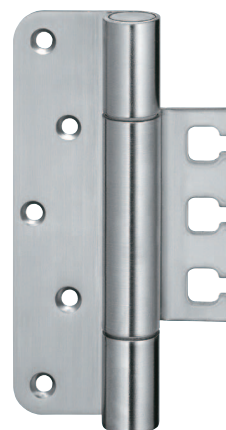

VARIANT® VX

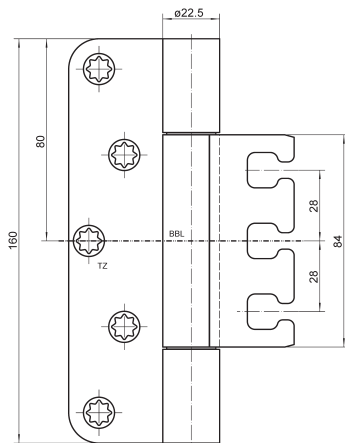

E.g. VX 7749/160-4/50 Care
door thickness 50 mm

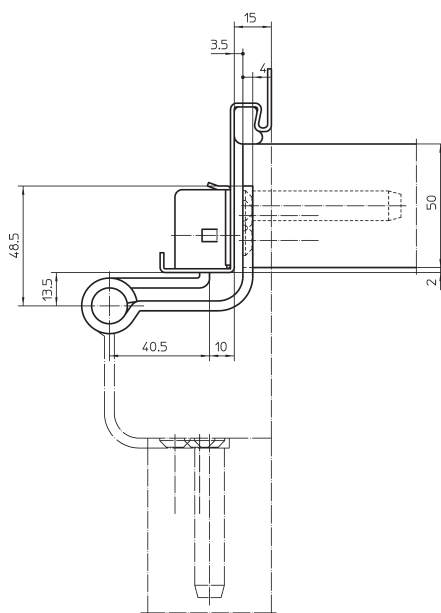

E.g. VX 7749/160-4/50 Care
door thickness 50 mm

VX 7749/160-4 Care

for unrebated heavy-duty doors in health care facilities

Hinge	unrebated	up to 100 kg
-------	-----------	--------------

Product features

- for unrebated heavy-duty doors in health care facilities
- free accessibility thanks to full frame opening
- for timber, steel or aluminium frames
- for 3D adjustable VARIANT VX receivers
- internal torsion-proof pin
- concealed, maintenance-free axial-radial slide bearing

Technical details

load capacity	i 2 hinges per door leaf (1x2m)	100.0 kg
knuckle length		160.0 mm
knuckle diameter		22.5 mm
pin diameter		10.0 mm
material thickness		4.0 mm
cutter diameter		24.0 mm
recommended screws		6.0x50.0 mm
opening angle		180°

Finishes

Satin Stainless Steel (040), other finishes available upon request

Combination

receiver	block frame	VX 7531 3D
	casing frame	VX 7532 3D
	blind frame	VX 7535 3D
	steel frame	VX 7511 3D
		VX 7512 3D
	aluminium frame	VX 7521 3D

Installation tools

jig		universal milling frame
template	No. 5 250353 5	VX 7749/160-4/40 Care VX 7749/160-4/45 Care VX 7749/160-4/50 Care VX 7749/160-4/65 Care VX 7749/160-4/70 Care

Note

i The load capacity mentioned above refers to two hinges per door leaf (1 x 2 m). Also the load capacities of the respective combined receiver have to be taken into consideration.

Furthermore, the different door thicknesses of 40 mm, 45 mm, 50 mm, 65 mm and 70 mm have to be taken into account. Please indicate exact hinge type when ordering. Also available with security pin (MSTS).

Model variants

VX 7749/160-4/40 Care	door thickness 40 mm	load capacity up to 100 kg
VX 7749/160-4/45 Care	door thickness 45 mm	load capacity up to 100 kg
VX 7749/160-4/50 Care	door thickness 50 mm	load capacity up to 100 kg
VX 7749/160-4/65 Care	door thickness 65 mm	load capacity up to 100 kg
VX 7749/160-4/70 Care	door thickness 70 mm	load capacity up to 100 kg

VARIANT® VX

VX 2501 3D N

for rebated and unrebated doors with block frames

block frame

Product features

- for rebated and unrebated doors
- for block frames
- for heavy-duty hinges VARIANT VX and VARIANT VXG
- with comfortable 3D adjustment (side + 2.0/- 4.0 mm, height +/- 3.0 mm, compression +/- 3.0 mm)
- adjustment with permanently fixed door

Technical details

load capacity	i 2 hinges per door leaf (1x2m)	200.0 kg
cutter diameter		24.0 mm

Finishes

blue galvanized (010)

Combination

hinge	VARIANT VX
	VARIANT VXG
cover angle	Series VX 2560 N
	Series VX 2570 N
cover plate	VX 2580 N
	VX 2590 N

Installation tools

jig		universal milling frame
receiver	VX 2501 3D N	template No. 5 251 086 5
cover angle	VX 2560 N	template No. 5 250 570 5
	VX 2570 N	template No. 5 251 087 5
cover plate	VX 2580 N	template No. 5 250 570 5
	VX 2590 N	template No. 5 251 089 5
	VX 2580 N	template No. 5 250 658 5
	VX 2590 N	template No. 5 251 087 5
	VX 2590 N	template No. 5 250 658 5
	VX 2590 N	template No. 5 251 089 5

Note

i The load capacity mentioned above refers to two hinges per door leaf (1 x 2 m). Also the load capacities of the respective combined hinge have to be taken into consideration.

For fixing the cover angle we recommend using wood screws minimum size 5.0 x 40.0 mm.

Cover angle/plate form a unit together with the receiver. They have to be ordered separately.

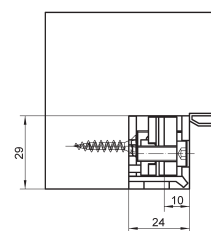
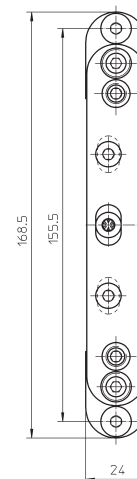

VARIANT® VX

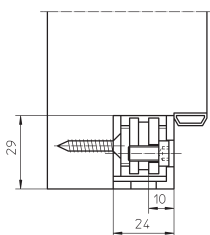
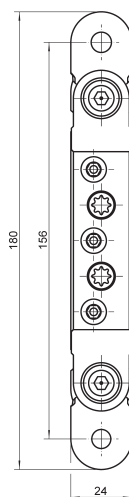

VX 7501 3D

for rebated and unrebated doors with block frames

block frame

Product features

- for rebated and unrebated doors
- for block frames
- for heavy-duty hinges VARIANT VX and VARIANT VXG
- continuous 3D adjustment (side +/- 3.0 mm, height +/- 3.0 mm, compression +/- 3.0 mm)

Technical details

load capacity	i 2 hinges per door leaf (1x2m)	200.0 kg
cutter diameter		24.0 mm

Finishes

blue galvanized (010), Stainless Steel untreated (041)

Combination

hinge	VARIANT VX
	VARIANT VXG
cover angle	Series VX 7560
	Series VX 7570
cover plate	VX 7580
	VX 7590

Installation tools

jig		universal milling frame
receiver	VX 7501 3D	template No. 5 250 568 5
		template No. 5 250 569 5
cover angle	VX 7560	template No. 5 250 570 5
	VX 7570	template No. 5 250 570 5
		template No. 5 250 657 5
cover plate	VX 7580	template No. 5 250 658 5
	VX 7590	template No. 5 250 657 5
		template No. 5 250 658 5

Note

i The load capacity mentioned above refers to two hinges per door leaf (1 x 2 m). Also the load capacities of the respective combined hinge have to be taken into consideration. Cover angle/plate form a unit together with the receiver. They have to be ordered separately. For fixing the cover angle chipboard screws of at least 6.0 x 40.0 mm are recommended.

VARIANT® VX

VX 7531 3D

for rebated and unrebated doors with block frames

block frame

Product features

- for extreme heavy rebated and unrebated heavy-duty doors
- for block frames
- for heavy-duty hinges VARIANT VX
- continuous 3D adjustment (side + 2.0/- 4.0 mm, height +/- 3.0 mm, compression +/- 3.0 mm)

Technical details

load capacity	2 hinges per door leaf (1x2m)	400.0 kg
cutter diameter		24.0 mm

Finishes

blue galvanized (010)

Combination

hinge		VARIANT VX
	cover angle	Series VX 7561 Series VX 7571
	cover plate	VX 7581 VX 7591

Installation tools

jig		universal milling frame drilling jig VX 7531 3D
receiver	VX 7531 3D	template No. 5 250 568 5 template No. 5 250 569 5
cover angle	VX 7561 VX 7571	template No. 5 251 088 5 template No. 5 251 088 5 template No. 5 250 657 5
cover plate	VX 7581 VX 7591	template No. 5 250 658 5 template No. 5 250 657 5 template No. 5 250 658 5

Note

i The load capacity mentioned above refers to two hinges per door leaf (1 x 2 m). Also the load capacities of the respective combined hinge have to be taken into consideration. Cover angle/plate form a unit together with the receiver. They have to be ordered separately. For fixing the cover angle chipboard screws of at least 5.0 x 40.0 mm are recommended.

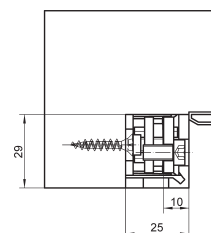
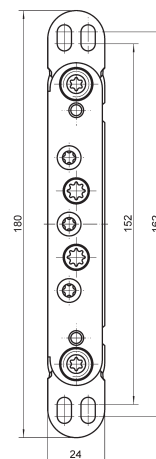

VARIANT® VX

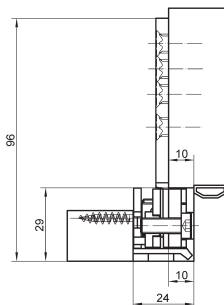
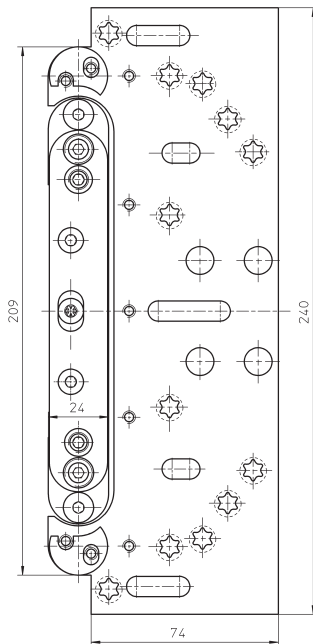

VX 2502 3D N

for rebated and unrebated doors with casing frames

casing frame

Product features

- for rebated and unrebated doors
- for casing frames
- for heavy-duty hinges VARIANT VX and VARIANT VXG
- with comfortable 3D adjustment (side + 2.0/- 4.0 mm, height +/- 3.0 mm, compression +/- 3.0 mm)
- adjustment with permanently fixed door

Technical details

load capacity	i 2 hinges per door leaf (1x2m)	200.0 kg
cutter diameter		24.0 mm

Finishes

blue galvanized (010)

Combination

hinge	VARIANT VX
	VARIANT VXG
cover angle	Series VX 2560 N
	Series VX 2570 N
cover plate	VX 2580 N
	VX 2590 N

Installation tools

jig		universal milling frame
receiver	VX 2502 3D N	template No. 5 251 087 5
cover angle	VX 2560 N	template No. 5 250 570 5
	VX 2570 N	template No. 5 250 570 5
cover plate		template No. 5 251 089 5
	VX 2580 N	template No. 5 250 658 5
	VX 2590 N	template No. 5 250 658 5
		template No. 5 251 089 5

Note

i The load capacity mentioned above refers to two hinges per door leaf (1 x 2 m). Also the load capacities of the respective combined hinge have to be taken into consideration.

Delivery includes packers for casing thicknesses of 22-28 mm.

Cover angle/plate form a unit together with the receiver. They have to be ordered separately.

In order to obtain the maximum load capacity, a sufficient fixing of frame and fixing plate/receiver in the masonry resp. partition wall frame is imperative.

VARIANT® VX

VX 7502 3D

for rebated and unrebated doors with casing frames

casing frame

Product features

- for rebated and unrebated doors
- for casing frames
- for heavy-duty hinges VARIANT VX and VARIANT VXG
- continuous 3D adjustment (side +/- 3.0 mm, height +/- 3.0 mm, compression +/- 3.0 mm)

Technical details

load capacity	i 2 hinges per door leaf (1x2m)	200.0 kg
cutter diameter		24.0 mm

Finishes

blue galvanized (010)

Combination

hinge	VARIANT VX
	VARIANT VXG
cover angle	Series VX 7560
cover plate	VX 7580

Installation tools

jig		universal milling frame
receiver	VX 7502 3D	template No. 5 250 568 5
cover angle	VX 7560	template No. 5 250 570 5
cover plate	VX 7580	template No. 5 250 658 5

Note

i The load capacity mentioned above refers to two hinges per door leaf (1 x 2 m). Also the load capacities of the respective combined hinge have to be taken into consideration.

Delivery includes packers for casing thicknesses of 22-28 mm.

Cover angle/plate form a unit together with the receiver. They have to be ordered separately.

In order to obtain the maximum load capacity, a sufficient fixing of frame and fixing plate/ receiver in the masonry resp. partition wall frame is imperative.

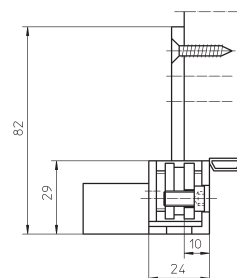
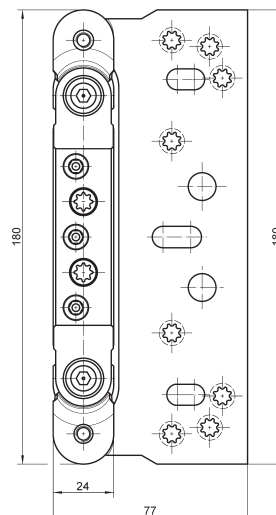

VARIANT® VX

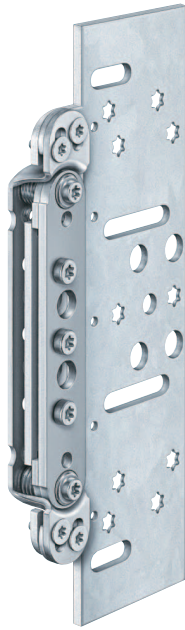

VX 7532 3D

for rebated and unrebated doors with casing frames

casing frame

Product features

- for rebated and unrebated heavy-duty doors
- for casing frames
- for heavy-duty hinges VARIANT VX
- continuous 3D adjustment (side + 2.0/- 4.0 mm, height +/- 3.0 mm, compression +/- 3.0 mm)

Technical details

load capacity	i 2 hinges per door leaf (1x2m)	200.0 kg
cutter diameter		24.0 mm

Finishes

blue galvanized (010)

Combination

hinge		VARIANT VX
cover angle		Series VX 7561 Series VX 7571
cover plate		VX 7581 VX 7591

Installation tools

jig		universal milling frame
receiver	VX 7532 3D	template No. 5 250 568 5
cover angle	VX 7561 VX 7571	template No. 5 251 088 5 template No. 5 251 088 5
cover plate	VX 7581 VX 7591	template No. 5 250 657 5 template No. 5 250 658 5 template No. 5 250 658 5 template No. 5 250 657 5

Note

i The load capacity mentioned above refers to two hinges per door leaf (1 x 2 m). Also the load capacities of the respective combined hinge have to be taken into consideration. Delivery includes packers for casing thicknesses of 22-28 mm. Cover angle/plate form a unit together with the receiver. They have to be ordered separately. In order to obtain the maximum load capacity, a sufficient fixing of frame and fixing plate/receiver in the masonry resp. partition wall frame is imperative.

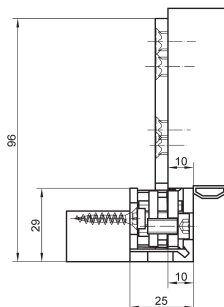
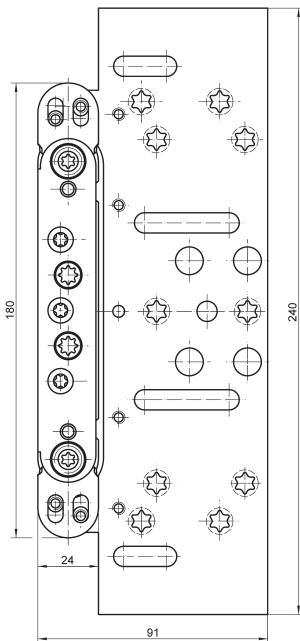

VARIANT® VX

VX 2505 3D N

for rebated and unrebated doors with blind frames

blind frame

Product features

- for rebated and unrebated doors
- for blind frame
- for heavy-duty hinges VARIANT VX and VARIANT VXG
- with comfortable 3D adjustment (side + 2.0/- 4.0 mm, height +/- 3.0 mm, compression +/- 3.0 mm)
- adjustment with permanently fixed door

Technical details

load capacity	i 2 hinges per door leaf (1x2m)	200.0 kg
cutter diameter		24.0 mm

Finishes

blue galvanized (010)

Combination

hinge	VARIANT VX
	VARIANT VXG
cover angle	Series VX 2560 N
cover plate	VX 2580 N

Installation tools

jig		universal milling frame
receiver	VX 2505 3D N	template No. 5 251 086 5
		template No. 5 251 090 5
cover angle	VX 2560 N	template No. 5 250 570 5
		template No. 5 251 087 5
cover plate	VX 2580 N	template No. 5 250 658 5
		template No. 5 251 087 5

Note

i The load capacity mentioned above refers to two hinges per door leaf (1 x 2 m). Also the load capacities of the respective combined hinge have to be taken into consideration. Cover angle/plate form a unit together with the receiver. They have to be ordered separately.

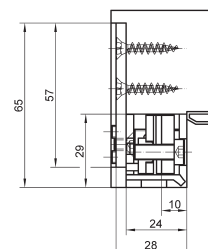
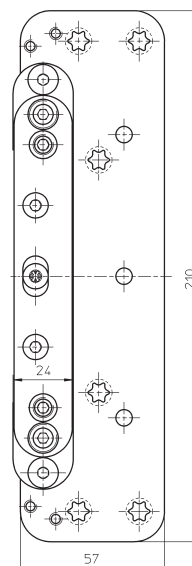

VARIANT® VX



VX 7505 3D

for rebated and unrebated doors with blind frames

blind frame

Product features

- for rebated and unrebated doors
- for blind frame
- for heavy-duty hinges VARIANT VX and VARIANT VXG
- continuous 3D adjustment (side +/- 3.0 mm, height +/- 3.0 mm, compression +/- 3.0 mm)

Technical details

load capacity	i 2 hinges per door leaf (1x2m)	200.0 kg
cutter diameter		24.0 mm

Finishes

blue galvanized (010)

Combination

hinge	VARIANT VX
	VARIANT VXG
cover angle	Series VX 7560
cover plate	VX 7580

Installation tools

jig		universal milling frame
receiver	VX 7505 3D	template No. 5 250 568 5
		template No. 5 250 569 5
		template No. 5 250 592 5
cover angle	VX 7560	template No. 5 250 570 5
cover plate	VX 7580	template No. 5 250 658 5

Note

i The load capacity mentioned above refers to two hinges per door leaf (1 x 2 m). Also the load capacities of the respective combined hinge have to be taken into consideration. Cover angle/plate form a unit together with the receiver. They have to be ordered separately.

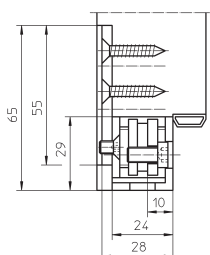
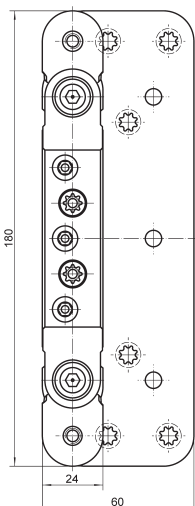

VARIANT® VX

VX 7535 3D

for rebated and unrebated doors with blind frame

blind frame

Product features

- for rebated and unrebated heavy-duty doors
- for blind frame
- for heavy-duty hinges VARIANT VX
- continuous 3D adjustment (side + 2.0/- 4.0 mm, height +/- 3.0 mm, compression +/- 3.0 mm)

Technical details

load capacity	i 2 hinges per door leaf (1x2m)	200.0 kg
cutter diameter		24.0 mm

Finishes

blue galvanized (010)

Combination

hinge		VARIANT VX
	cover angle	Series VX 7561
	cover plate	VX 7581

Installation tools

jig		universal milling frame
receiver	VX 7535 3D	template No. 5 250 568 5
		template No. 5 250 569 5
		template No. 5 251 091 5
cover angle	VX 7561	template No. 5 251 088 5
cover plate	VX 7581	template No. 5 250 658 5

Note

i The load capacity mentioned above refers to two hinges per door leaf (1 x 2 m). Also the load capacities of the respective combined hinge have to be taken into consideration. Cover angle/plate form a unit together with the receiver. They have to be ordered separately.

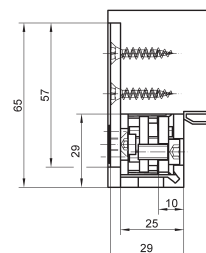
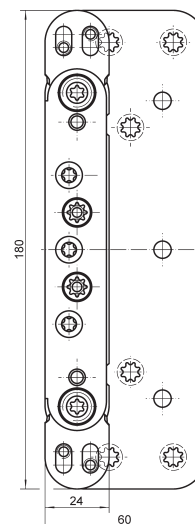

VARIANT® VX



VX 2511 3D

for rebated and unrebated doors with steel frames

steel frame

Product features

- for rebated and unrebated doors
- for steel frames
- for heavy-duty hinges VARIANT VX and VARIANT VXG
- with comfortable 3D adjustment (side +/- 3.0 mm, height +/- 3.0 mm, compression +/- 3.0 mm)
- with weld nuts

Technical details

load capacity	i 2 hinges per door leaf (1x2m)	200.0 kg
---------------	--	----------

Finishes

blue galvanized (010)

Combination

hinge	VARIANT VX VARIANT VXG
-------	---------------------------

Note

i The load capacity mentioned above refers to two hinges per door leaf (1 x 2 m). Also the load capacities of the respective combined hinge have to be taken into consideration.

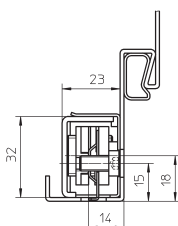
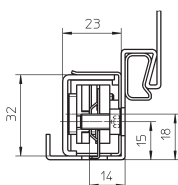
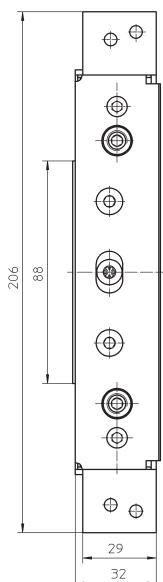

VARIANT® VX

VX 7511 3D / VX 7512 3D

for rebated and unrebated doors with steel frames

steel frames

Product features

- for rebated and unrebated doors
- for steel frames
- for heavy-duty hinges VARIANT VX and VARIANT VXG
- continuous 3D adjustment (side +/- 3.0 mm, height +/- 3.0 mm, compression +/- 3.0 mm)
- with or without welding dimples

Technical details

load capacity **i** 2 hinges per door leaf (1x2m) 200.0 kg

Finishes

blue galvanized (010), Stainless Steel untreated (041)

Combination

hinge VARIANT VX
VARIANT VXG

Note

i The load capacity mentioned above refers to two hinges per door leaf (1 x 2 m). Also the load capacities of the respective combined hinge have to be taken into consideration.

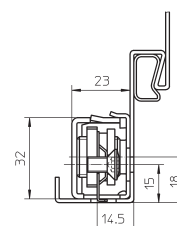
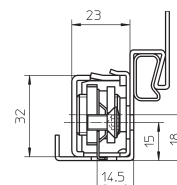
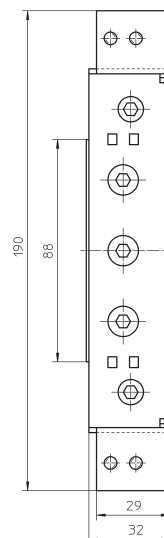

VARIANT® VX



VX 7521 3D

for rebated and unrebated doors with aluminium frames

aluminium frames

Product features

- for rebated and unrebated doors
- for aluminium frames
- for heavy-duty hinges VARIANT VX and VARIANT VXG
- continuous 3D adjustment (side +/- 3.0 mm, height +/- 3.0 mm, compression +/- 3.0 mm)

Technical details

load capacity	i 2 hinges per door leaf (1x2m)	160.0 kg
---------------	--	----------

Finishes

blue galvanized (010)

Combination

hinge	VARIANT VX
	VARIANT VXG

Note

i The load capacity mentioned above refers to two hinges per door leaf (1 x 2 m). Also the load capacities of the respective combined hinge have to be taken into consideration.

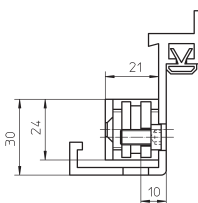
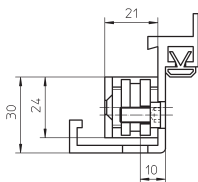
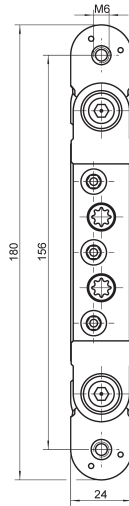

VARIANT® VX

Series VX 2560 N

for VARIANT VX 25.. 3D receiver series

cover angle

Product features

- for VARIANT VX 25.. 3D receiver series

Finishes

satin nickelled/F2 (018), polished brassed (030), Satin Stainless Steel (040), polished Stainless Steel (042), other finishes available upon request

Combination

receiver	block frame	VX 2501 3D N
	casing frame	VX 2502 3D N
	blind frame	VX 2505 3D N

Note

Cover angle/plate form a unit together with the receiver.
They have to be ordered separately.

Alternative angle

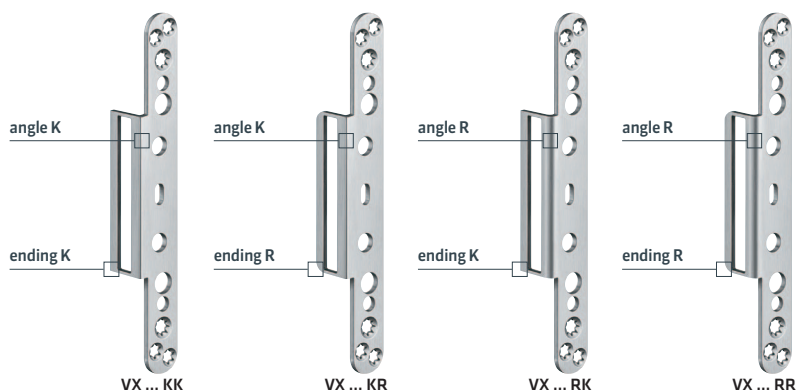

angle K = angular
angle R = R3,5

ending K = angular
ending R = R6

Model variants

VX 2560 KK N

VX 2560 KR N

VX 2560 RK N

VX 2560 RR N

Detailed information available in our PRODUCTSELECTOR at www.simonswerk.com

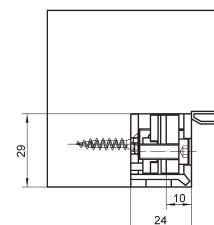
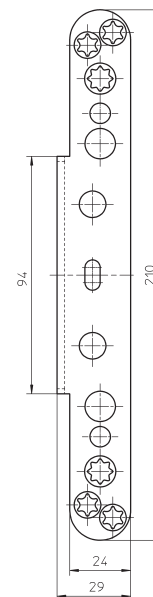

VARIANT® VX



Series VX 2570 N

for receivers VARIANT VX 2501 3D N and VARIANT VX 2502 3D N

cover angle

Product features

- for receivers VARIANT VX 2501 3D N and VARIANT VX 2502 3D N

Finishes

Satin Stainless Steel (040)

Combination

receiver	block frame	VX 2501 3D N
	casing frame	VX 2502 3D N

Note

Cover angle/plate form a unit together with the receiver.
They have to be ordered separately.

Alternative angle

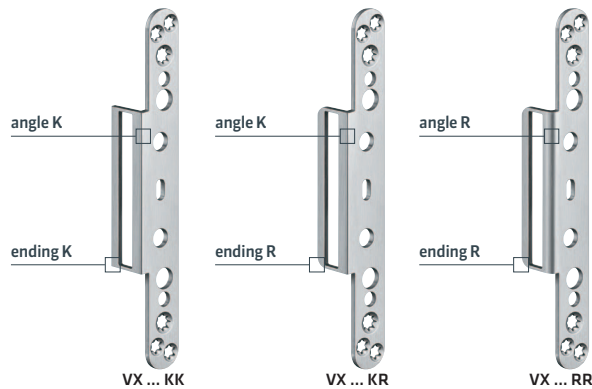

angle K = angular ending K = angular
angle R = R3,5 ending R = R6

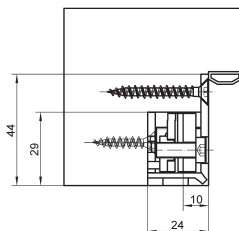
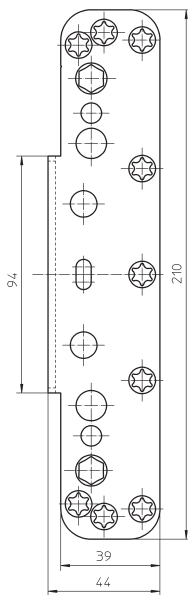

Model variants

VX 2570 KK N

VX 2570 KR N

VX 2570 RR N

Detailed information available in our PRODUCTSELECTOR at www.simonswerk.com

VARIANT® VX

VX 2580 N

for receivers of series VARIANT VX 25.. 3D N

cover plate

Product features

- for receivers of series VARIANT VX 25.. 3D N

Finishes

satin nickelled/F2 (018), Satin Stainless Steel (040)

Combination

receiver	block frame	VX 2501 3D N
	casing frame	VX 2502 3D N
	blind frame	VX 2505 3D N

Note

Cover angle/plate form a unit together with the receiver.
They have to be ordered separately.

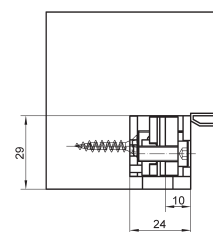
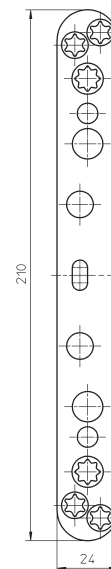

VARIANT® VX



VX 2590 N

for receivers VARIANT VX 2501 3D N and VARIANT VX 2502 3D N

cover plate

Product features

- for receivers VARIANT VX 2501 3D N and VARIANT VX 2502 3D N

Finishes

Satin Stainless Steel (040)

Combination

receiver	block frame	VX 2501 3D N
	casing frame	VX 2502 3D N

Note

Cover angle/plate form a unit together with the receiver.
They have to be ordered separately.

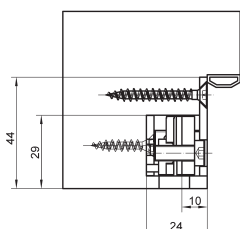
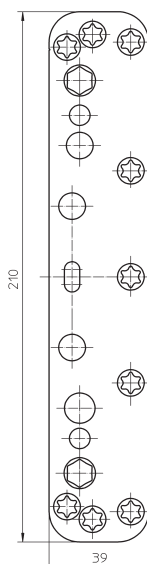

VARIANT® VX

Series VX 7560

for VARIANT VX 75.. 3D receiver series

cover angle

Product features

- for VARIANT VX 75.. 3D receiver series

Finishes

blue galvanized (010), satin nickelled/F2 (018), polished brassed (030), satin chromed/F1 (037), Satin Stainless Steel (040), polished Stainless Steel (042), Stainless Steel/316 series (043), RAL 9005 Matte Black (107), Bronze Finish (174), Bronze Finish light (175), Bronze Finish dark (176), other finishes available upon request

Combination

receiver	block frame	VX 7501 3D
	casing frame	VX 7502 3D
	blind frame	VX 7505 3D

Note

Cover angle/plate form a unit together with the receiver.
They have to be ordered separately.

Alternative angle

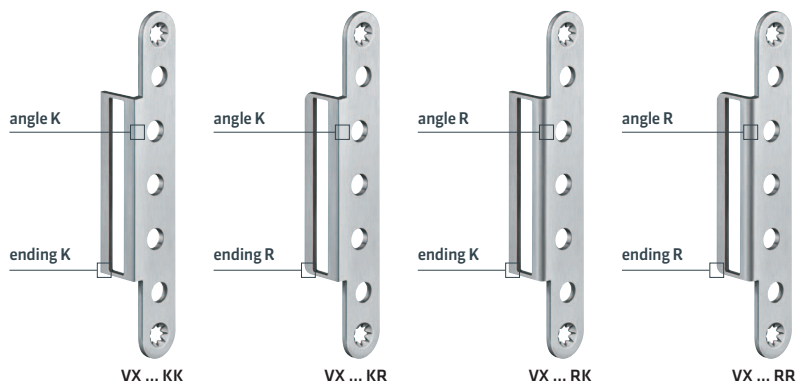

angle K = angular ending K = angular
angle R = R3,5 ending R = R6

Model variants

- VX 7560 KK
- VX 7560 KR
- VX 7560 RK
- VX 7560 RR

Detailed information available in our PRODUCTSELECTOR at www.simonswerk.com

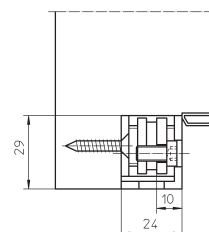
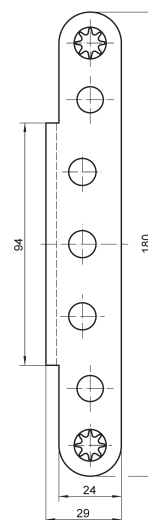

VARIANT® VX



VX 7561 KK

for receivers VARIANT VX 7531 3D, VX 7532 3D and VX 7535 3D

cover angle

Product features

- for receivers VARIANT VX 7531 3D, VX 7532 3D and VX 7535 3D

Finishes

satin nickelled/F2 (018), satin chromed/F1 (037), Satin Stainless Steel (040), RAL 9005 Matte Black (107)

Combination

receiver	block frame	VX 7531 3D
	casing frame	VX 7532 3D
	blind frame	VX 7535 3D

Note

Cover angle/plate form a unit together with the receiver.
They have to be ordered separately.

Alternative angle

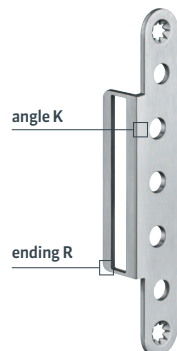

VX ... KR

angle K = angular ending K = angular
angle R = R3,5 ending R = R6

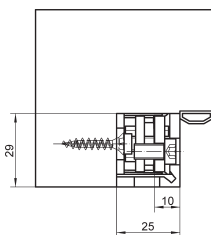
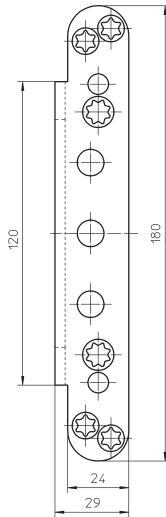

VARIANT® VX

Series VX 7570

for VARIANT VX 7501 3D receiver

cover angle

Product features

- for VARIANT VX 7501 3D receiver

Finishes

Satin Stainless Steel (040)

Combination

receiver	block frame	VX 7501 3D
----------	-------------	------------

Note

Cover angle/plate form a unit together with the receiver.
They have to be ordered separately.

Alternative angle

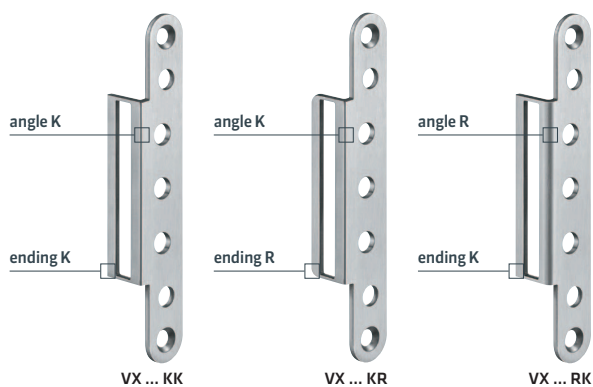

angle K = angular ending K = angular
 angle R = R3,5 ending R = R6

Model variants

VX 7570 KK

VX 7570 KR

VX 7570 RK

Detailed information available in our PRODUCTSELECTOR at www.simonswerk.com

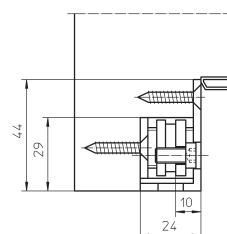
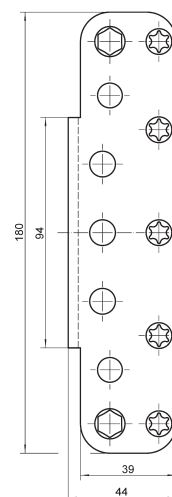

VARIANT® VX



VX 7571 KK

for receivers VARIANT VX 7531 3D and VX 7532 3D

cover angle

Product features

- for receivers VARIANT VX 7531 3D and VX 7532 3D
- square-edged angle and ending

Finishes

Satin Stainless Steel (040)

Combination

receiver	block frame	VX 7531 3D
	casing frame	VX 7532 3D

Note

Cover angle/plate form a unit together with the receiver.
They have to be ordered separately.

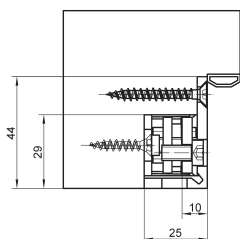
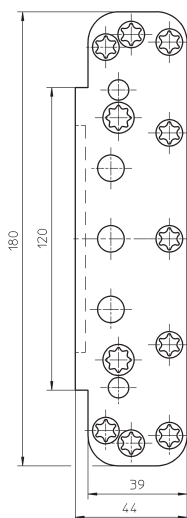

VARIANT® VX

VX 7580

for VARIANT VX 75.. 3D receiver series

cover plate

Product features

- for VARIANT VX 75.. 3D receiver series

Finishes

satin nickelled/F2 (018), Satin Stainless Steel (040)

Combination

receiver	block frame	VX 7501 3D
	casing frame	VX 7502 3D
	blind frame	VX 7505 3D

Note

Cover angle/plate form a unit together with the receiver.

They have to be ordered separately.

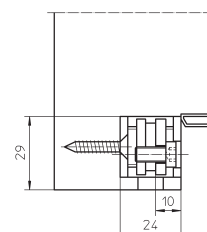
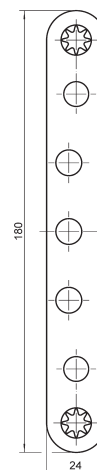

VARIANT® VX



VX 7581

for receivers VARIANT VX 7531 3D, VX 7532 3D and VX 7535 3D

cover plate

Product features

- for receivers VARIANT VX 7531 3D, VX 7532 3D and VX 7535 3D

Finishes

satin nickelled/F2 (018), Satin Stainless Steel (040)

Combination

receiver	block frame	VX 7531 3D
	casing frame	VX 7532 3D
	blind frame	VX 7535 3D

Note

Cover angle/plate form a unit together with the receiver.
They have to be ordered separately.

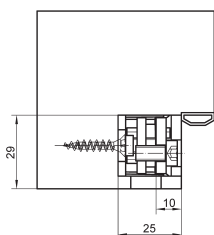
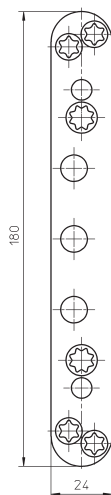

VARIANT® VX

VX 7590

for VARIANT VX 7501 3D receiver

cover plate

Product features

- for VARIANT VX 7501 3D receiver

Finishes

Satin Stainless Steel (040)

Combination

receiver	block frame	VX 7501 3D
----------	-------------	------------

Note

Cover angle/plate form a unit together with the receiver.
They have to be ordered separately.

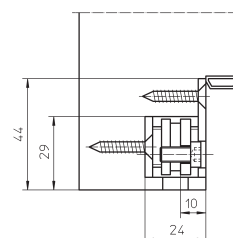
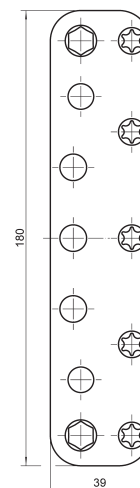

VARIANT® VX



VX 7591

for receivers VARIANT VX 7531 3D and VX 7532 3D

cover plate

Product features

- for receivers VARIANT VX 7531 3D and VX 7532 3D

Finishes

Satin Stainless Steel (040)

Combination

receiver	block frame	VX 7531 3D
	casing frame	VX 7532 3D

Note

Cover angle/plate form a unit together with the receiver.
They have to be ordered separately.

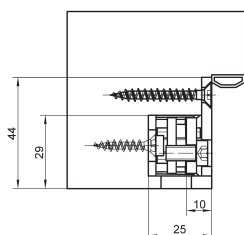
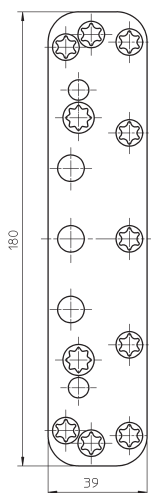

VARIANT® VX

Pin VN/VX 160 MSTS RC

Hardened pin for added protection against hacksaw attack

accessories

hinge pin

Finishes

galvanised with stainless steel head

Combination

hinge

VX 160 mm





LOAD CAPACITIES

When selecting or deciding on a hinge, the load alone is already often viewed as being identical to the weight of the door. However, the hinge load can often be several times the door weight, caused by various influential factors.

Even taking these various criteria into account, an additional reserve should always still be included when selecting the hinge. Especially in public buildings where extra loads are incurred due to the high opening frequency and stress which is not always calculable (kindergarten, hospitals etc.), sufficiently dimensioned hinges should be used even if this would not have been necessary merely based on the door weight as such.

Reference details

The load specifications for SIMONSWERK hinges are based on a maximum door weight. Additionally, the named influential factors must be taken into account for hinge loads.

All indications are based on following references:

Door leaf dimensions	1000 x 2000 mm
Use of	2 hinges
Hinge distance	1435 mm

Third hinge

In addition to the factors mentioned above the use of a third hinge can have a significant impact on the load capacity. In practice often a third hinge is located in the middle of the door in order to meet the optical demands and to minimise warping in the centre of the door. Under certain circumstances however it may be useful or even necessary to additionally support the upper hinge which takes most of the major tractive forces - this could be true, for instance, in the case of extra-wide doors (>1000 mm), where additional forces occur due to the lever action. For these applications the third hinge has to be located in the upper third since only then the load capacity of the hinge is positively influenced. The door regulations stipulate the use of a third 350 mm hinge (please note: new measurement) below the upper one (with reference to the upper HRL). In the case of unregulated units (e.g. exterior doors), SIMONSWERK recommends reducing this size to as far as 250 mm, depending on the knuckle length.

Doors with excess widths

SIMONSWERK heavy-duty hinges have generally been designed for the indicated load capacities. Please take into account that for doors wider than 100 cm and the hinge spacing remaining constant the load capacities are reduced in percentages by the same ratio as the standard door width of 100 cm is exceeded (e.g. door width 125 cm = load capacity /. 25 %). An accurate, professional fitting in accordance with the SIMONSWERK installation instructions is always a prerequisite.

An accurate, professional fitting in accordance with the SIMONSWERK installation instructions is always a prerequisite.

Installation site (residential building, public building, school, administration, barracks, kindergarten etc.)

Type of material of the element

Frequency of operation

Door dimensions (e.g. excess widths)

Positioning of hinges

Assembly of hinges

Outward opening doors (porch)

Door stop

Door closer

Wall soffits

Swing-door operator

Closing sequence control systems, etc.

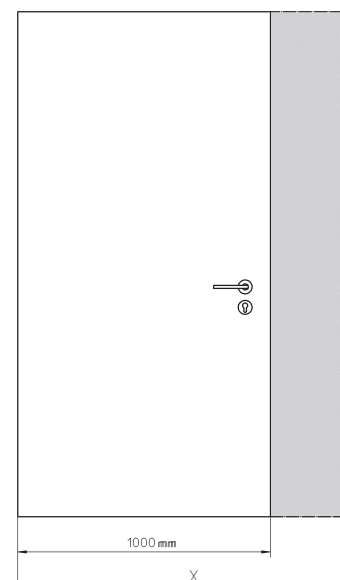
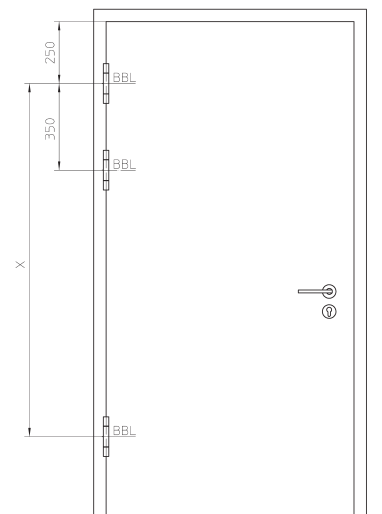

LOAD CAPACITIES

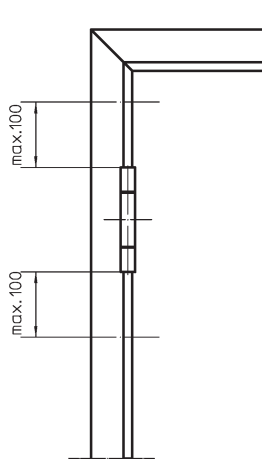

Frame fixing

To achieve a max. load capacity of a door hinge a proper and appropriate assembly of all components is compulsory. Special emphasis shall be given to the fixing of the door element to the wall. Especially closed frames, whether made of steel, aluminium or derived timber boards, often show a higher instability, therefore it is necessary to pay attention to a secure fixing to the brickwork or framework. Foaming alone in this area is not recommended for door weights >60 kg. Here, a force-fitted connection must be created via a screw or plug connection through the receiver, or max. 100 mm from the outer edge of the hinges.

Door closers

When door closers are used, SIMONSWERK recommends the use of a third hinge in the upper third of the door. The correct adjustment of the closer is a fundamental requirement for a long-lasting, problem-free functioning.

Door drives

When a swing-door operator is used, SIMONSWERK recommends using a total of four hinges, placed in two pairs at the top and the bottom. The internal distance between a pair of hinges should not exceed 350 mm (please note: new measurement).

Closing sequence control systems

When closing sequence control systems are used with double-leaf doors, it is important to ensure that a cushioned locking device is used for the active leaf, so that the forces are not transmitted to the hinges 1:1. In this case, SIMONSWERK recommends using a third hinge in the upper third of the door.

Wall openings, door stoppers

Factors such as door stoppers, projecting wall openings or similar cannot be measured or estimated and need to be considered individually, due to the lever action and forces that may occur if the door is opened too far resp. beyond a defined level. As a result of the doors' masses/weights, this can quickly lead to damage to the fastening, the hinges or similar. If it is necessary to use a door stopper, this should either be mounted on the wall or, instead, on the floor placed at 75% of the door's width away from the hinge axis in the direction of the lock.

Miscellaneous

The points given here are simply guidelines. In practice, it may very well make sense, depending on the door's composition, usage levels, location, etc., to take the above factors into account even for door widths ≤ 1000 mm. This needs to be decided on a case-by-case basis. In any case, care must be taken to ensure that the hinges are of a sufficient size to be able to cover the extraneous factors.

OPTIONS

Screws

The countersunk screw holes on SIMONSWERK heavy-duty hinges are designed for current German wood and chipboard screws (e.g. Spax). For use in practice we recommend screws according to DIN 7997 with a diameter of 4.5–5.0 mm. The countersunk holes of hinges made of 4 mm thick material are designed for a 6 mm screw diameter. The outer fastening screws for the covers of the VARIANT VX series should be at least 6 x 40 mm.

In general we recommend that screw holes are predrilled to ensure an optimum hold and thereby guarantee the stated load capacities. When SIMONSWERK hinges are used on acetylated, acidic or otherwise modified timbers, care must be taken to select the corresponding fixing tools / fastening screws.

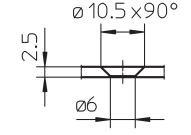
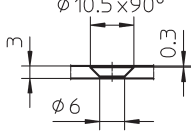
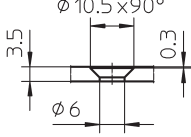
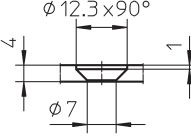
Material Gauge	Countersink
2.5 mm	
3.0 mm	
3.5 mm	
4.0 mm	

Security Pin (MSTS)

For the use on outward opening doors all SIMONSWERK hinges with continuous hinge pin are available with non removable pin. Depending on the hinge range, different techniques are applied to either secure the hinge pin or the pin screws against knocking-out or unscrewing (see image).

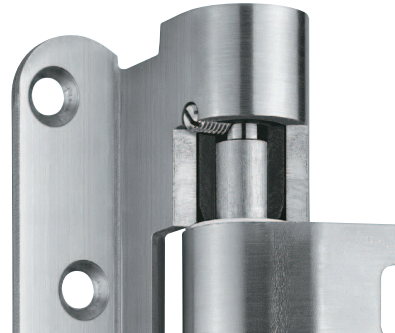

OPTIONS



Reinforcing dowel (TZ)

Depending on the application area, design and door usage, the use of reinforcing dowels may be recommended to stabilise the hinge leaves. Reinforcing dowels relieve the load on the fastening screws and stabilise the hinge leaves in the door leaf hole. Hinges with a height of 160 mm or 120 mm can be fitted with an additional reinforcing dowel in the centre screw hole. The reinforcing dowel is to be ordered separately. With a material thickness of 3.0 mm or 3.5 mm, the reinforcing dowel will need to be 12 x 50 mm (M 5 screw). With a material thickness of 4.0 mm, use a reinforcing dowel of 12 x 60 mm (M 6 screw).

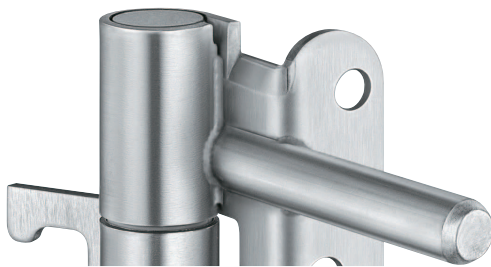

S-dowel (S)

SIMONSWERK hinges are suitable for the use on burglar resistant doors. On several occasions respective evidence was provided on various door elements. Especially for applications according to DIN EN 1627 ff resistance class 3 and higher the use of hinges with S-dowels is recommended. Unlike reinforcing dowels, these dowels are welded to the hinge and care for a stabilization of the hinge and are capable to absorb forces evolving from lever tools.



Overlap seal

For soundproof doors SIMONSWERK hinges are available as FD version (acoustic seal). These hinges are equipped with a groove for the continuous acoustic seal which does not need to be notched in the area of the hinge.

Plaster proof receivers

The plaster proof receivers are designed in a way that penetration of mortar is prevented. When using thin fluid backfill material, an additional insulation, e.g. with self-adhesive tape, is highly recommended.

Custom-made designs

If you have special designs and none of the hinges featured on this website is suitable, please send us a dimensioned cross sectional drawing of the component design, if possible on a 1:1 scale – ideally in CAD format, e.g. DXF. SIMONSWERK will quickly check whether any of our hinges can be modified to suit your requirements.

TESTING, APPROVAL & QUALITY

CE mark

The CE mark forms the basis for a free movement of goods within the European Union. This applies now to hinges for doors and windows as well. By means of mandate 101 released by the European Committee for Standardization (CEN) and by adoption of DIN EN 1935 into the Building Regulation List B by the German Institute for Building Technologies, this is obligatory for hinges on fire and smoke resistant doors and on doors to escape and rescue routes. After comprehensive tests based on above standards "single-axis hinges on doors and windows" the ift Rosenheim has issued the EU conformity certificate for all relevant SIMONSWERK hinge types.

Tests to DIN EN 1935 are generally conducted with one supporting hinge only. SIMONSWERK hinges are generally tested acc. to the standard with the largest possible number of closing operations - 200,000 cycles. Furthermore many hinges were tested with a load value significantly higher than prescribed according to the rules. The consistent product quality is now guaranteed by an inhouse production control system and by the annual audit done by ift Rosenheim.

All CE-certified products have a classification key. This 8-digit code contains all essential information about properties, load capacity and application field of the hinge.

In practice it is expected that tenders will mainly refer to the first digit of this code, the so-called application class. Almost all SIMONSWERK hinges have been tested and certified to the highest application class - very heavy usage. With the CE mark SIMONSWERK has a further quality label, now valid throughout Europe, which underlines once more the high quality of SIMONSWERK products.

On 01/07/13, the new Construction Products' Regulation came into effect. In addition to the product identification, the provision of so-called Declarations of Performance is a key requirement. SIMONSWERK provides these Declarations of Performance - divided into six different groups - at www.simonswerk.de/dop.

International testings

Safety of use, even under extreme conditions, is our concern. In order to achieve this we have our products tested not only in Germany but also worldwide by International institutes. Thoroughness, elaborateness and experience of institutes such as Underwriters Laboratories having made decisive contributions to improvements regarding fire protection in the USA since 1894, and Warringtonfire, the largest and most modern independent fire test laboratory located in Europe, Asia and Australia, comply with the test criteria related to SIMONSWERK door hinges.

Any product that leaves SIMONSWERK and is certified by any of these institutes, can unhesitatingly be used in international building projects in accordance with the respective regulations. Such compatibility convinces architects and planners as well as door manufacturers.

Our longtime experience, combined with the expertise of these well-reputed testing institutes, creates optimally designed functional elements. We look forward to receiving your call in order to specify the ideal hinge for your individual application.



warringtonfire



TESTING, APPROVAL & QUALITY



ANSI/BHMA A156.1 Butts and Hinges

This Standard establishes requirements for lightweight, standard weight, heavy weight and detention hinges. Cycle tests, lateral and vertical wear tests, friction tests, strength tests, finish tests, and material and dimensional requirements are included. Tests described in this Standard are performed under laboratory conditions. In actual usage, results vary because of installation, maintenance and environmental conditions.

Classification code

Classification of hinges to EN 1935

The European standard EN 1935 determines the test methods and requirements of single axis screw-on hinges and hinges with fixed pins for entrance doors and windows and classifies them referring to an 8-digit designation system.
Classification key according to EN 1935

Description of hinges according to EAD (European Assessment Document)

EAD specifies test procedures and requirements for multi-axis hinges and classifies them with an 8-digit coding system.
Classification key according to EAD

SIMONSWERK – THE ORIGINAL HINGE SYSTEMS

SIMONSWERK is a leading manufacturer of heavy-duty, high performance hinge systems, producing premium hinges for over 130 years. As an industry pioneer for adjustable concealed door hinge systems, SIMONSWERK has built an impressive and extensive product offering including a wide range of architectural finishes for high-traffic and heavy-use doors.

With a hinge system for nearly every application, SIMONSWERK constantly strives to meet the demand for innovative design solutions, utilizing functional tools to ensure a simple and smooth installation process. In addition, SIMONSWERK makes every effort to offer an outstanding customer service experience.

Behörde für Stadtentwicklung und Umwelt, Hamburg
ARCHITECTS: Sauerbruch Hutton, Berlin
SIMONSWERK: VARIANT® VX



QUALITY AND INNOVATION

The SIMONSWERK brand stands for innovation and high standards of quality and service. These cornerstones date back as far as 1889, with customized solutions leading to the development of new products every year.

SIMONSWERK's quality requirements begin with the products, specifically in the selection of raw materials. Using high-quality materials allows for the largest possible freedom of design, providing diverse options for surface refinement and protection against corrosion.

State-of-the-art resources, including the latest manufacturing techniques and highly flexible automated production processes, make SIMONSWERK a competent partner for all aspects of door hinge technology. To meet the technical, safety and design requirements of modern architecture, SIMONSWERK hinge systems feature precise functioning, often exceeding demands and expectations.

A company's innovative strength is expressed through its competence and its responsibility to its customers in the marketplace. Longevity, top-quality products, and creative thinking give SIMONSWERK the ability to open new markets with new ideas.



SIMONSWERK – THE COMPANY FACTS

SIMONSWERK, headquartered in Rheda-Wiedenbrück, Germany, is a leading manufacturer of sophisticated hinges and hinge systems for more than 130 years. Today with more than 600 employees, SIMONSWERK currently ranks amongst the leading suppliers of hinges and hinge systems in Europe.

With the strategic focus as a full-service provider, SIMONSWERK offers a wide product range of hinges and hinge systems for residential, commercial and entrance doors. For the various designs of doors in timber, steel, aluminum, PVC and glass, over 2000 models are used in nearly 5,000 versions. All products are invariably “Made in Germany”. With this range SIMONSWERK is the absolute market leader in Germany.

At present the company is active in over 70 international markets, 35 of those are served consistently by independent subsidiaries, by representatives or own staff members.



SERVICE – COMPREHENSIVE EXPERTISE FOR YOUR DAILY WORK

We are happy to provide you with all the documentation you need to calculate which is the most suitable hinge system for your requirements. Please contact us: we would be delighted to work with you to choose the best solution – from high-quality standard sets right up to the most complex solutions.

Please visit our home page for any information not included in this brochure. You will find it easy to navigate through our user-friendly website to arrive at the detailed, comprehensive solutions.

All our brochures and data sheets can be requested in a printed version, or you can simply download them on the spot – and the same applies to our fitting instructions and milling data.

www.simonswerk.com

VISIT OUR PRODUCTSELECTOR

Whether you are a manufacturer, trade partner or designer, at www.simonswerk.com you can find precise, detailed product descriptions that will help you to choose the most suitable hinge systems.



CONTAINS

VX 7939/100	VX 2502 3D N
VX 7939/120	VX 7502 3D
VX 7939/160 Planum	VX 7532 3D
VX 7939/160	VX 2505 3D N
VX 7939/160 S WK MSTs	VX 7505 3D
VX 7939/160-4	VX 7535 3D
VX 7939/160-4 VBRplus	VX 2511 3D
VX 7728/100	VX 7511/7512 3D
VX 7728/120	VX 7521 3D
VX 7859/120	Series VX 2560 N
VX 7728/160	Series VX 2570 N
VX 7859/160-4	VX 2580 N
VX 7729/100	VX 2590 N
VX 7729/120	Series VX 7560
VX 7729/160 Planum	VX 7561 KK
VX 7729/160-4 HA Set	Series VX 7570
VX 7729/160	VX 7571 KK
VX 7729/160-4	VX 7580
VX 7729/160-4 VBRplus	VX 7581
VX 7749/160-4 Care	VX 7590
VX 2501 3D N	VX 7591
VX 7501 3D	Pin VX 160 MSTs RC
VX 7531 3D	

PLEASE VISIT THE PRODUCTSELECTOR AT
www.simonswerk.com

SIMONSWERK GmbH

Bosfelder Weg 5
33378 Rheda-Wiedenbrück
Germany

+49 (0)5242/413-0

+49 (0)5242/413-260

sales@simonswerk.de
www.simonswerk.com

